

# Safety and Care Guidelines

- 1.Ensure the assembly surface is level and stable before proceeding with installation.
- 2.Verify that all listed components are present and accounted for prior to assembly.
- 3.Avoid direct contact with board surfaces by hard or sharp objects during use.
- 4.Basic DIY proficiency is sufficient for assembly when following the instructions carefully.
- 5.Clean surfaces easily with a dry or slightly damp soft cloth. Do not use chemical cleaners.
- 6.For any difficulties or inquiries during assembly, please contact the authorized retailer or the manufacturer's customer service department.

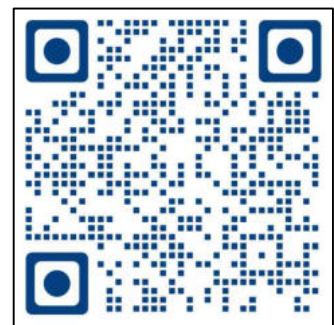
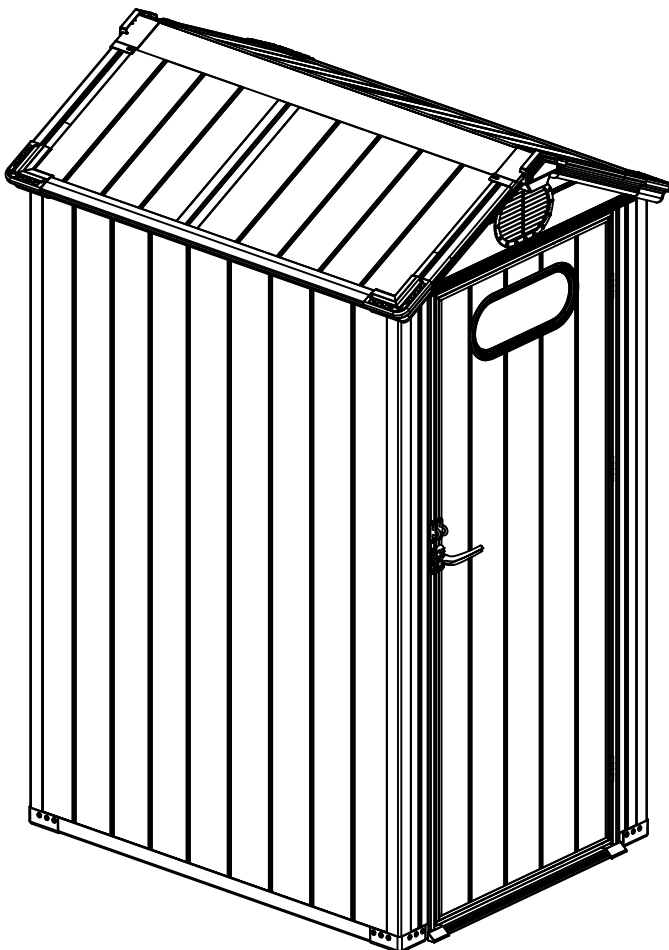

Prior to installation, please scan the QR code to view the assembly video.

# Assembly Instruction Manual

## Table of Contents

Step 01 Assembling the Base Frame

01-01/01-14

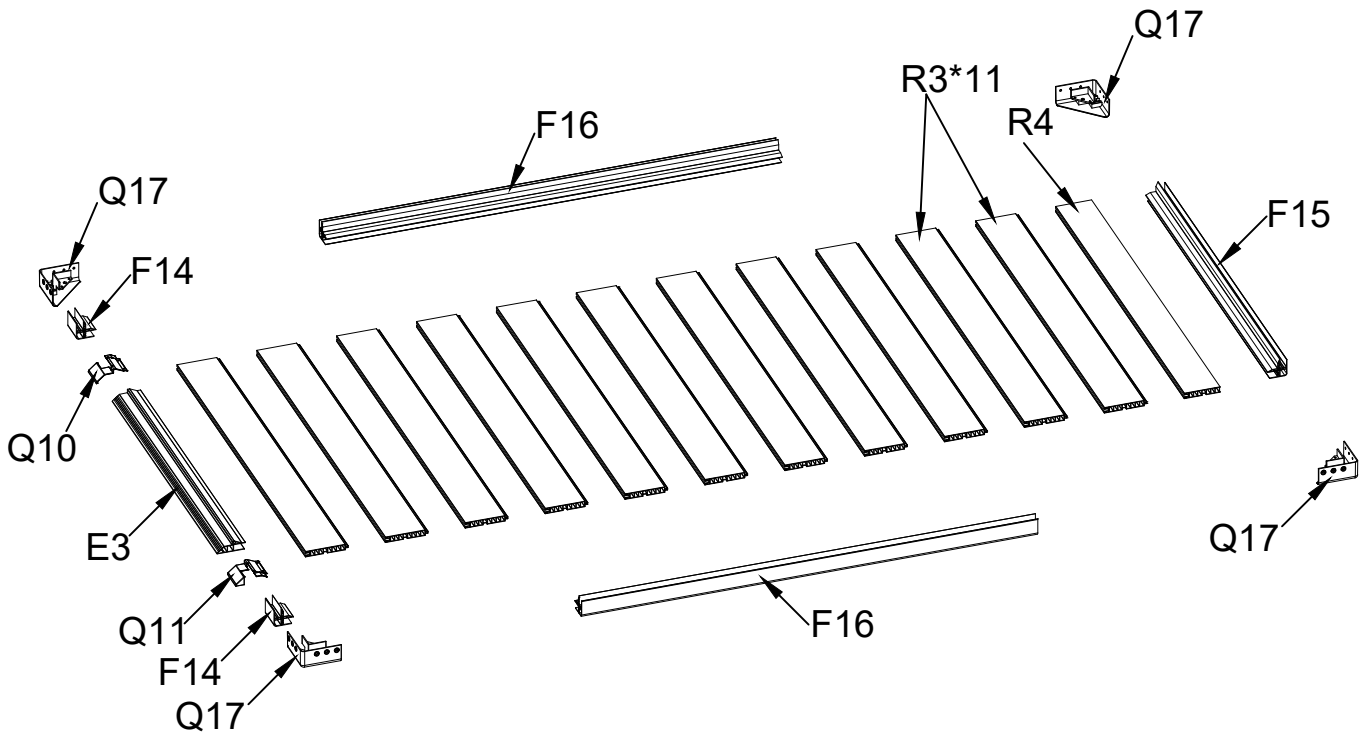

# Assembly Instruction Manual

## Table of Contents

Step 02 Assembling the Side Walls

02-01/02-29

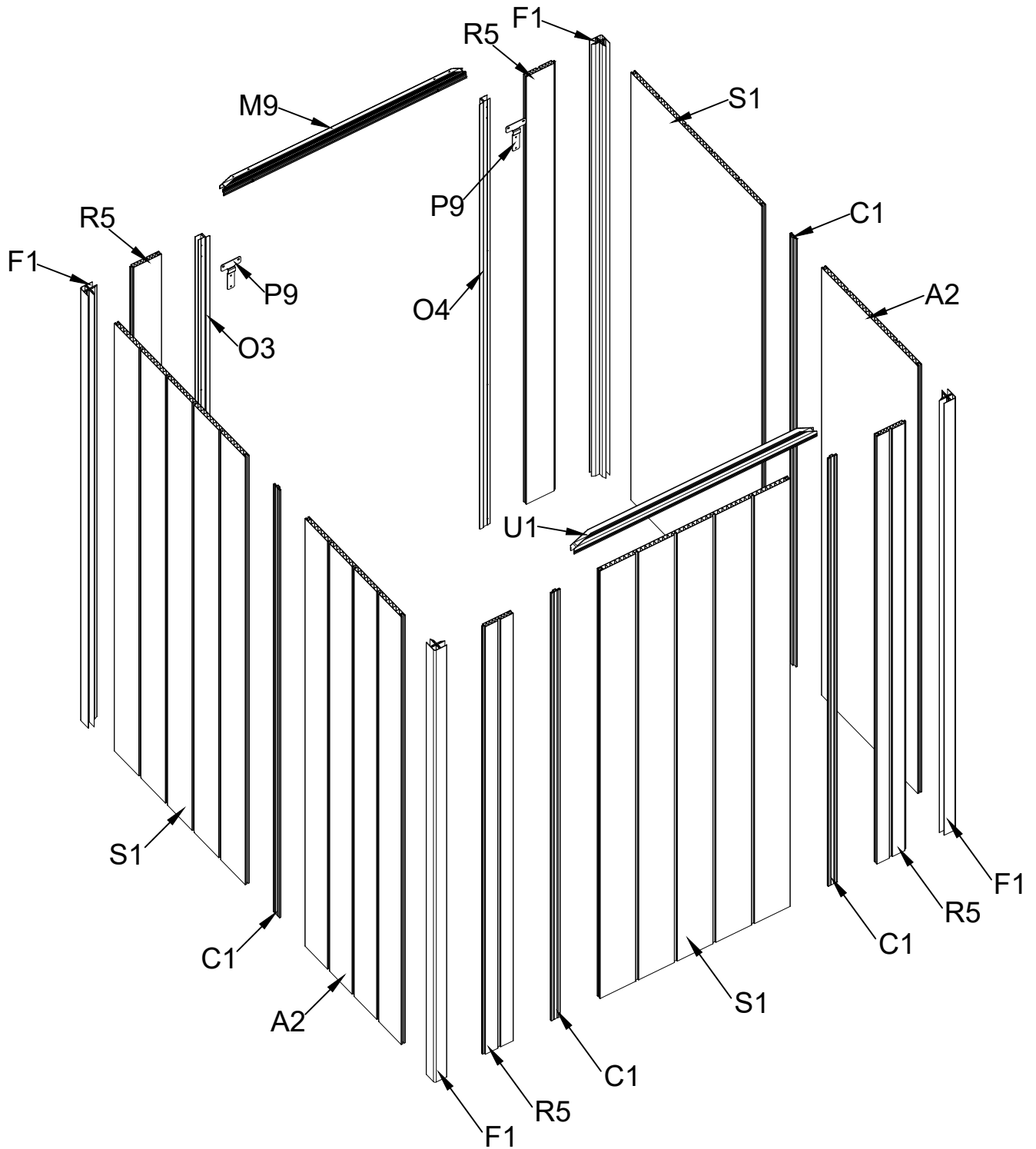

# Assembly Instruction Manual

## Table of Contents

Step 03 Installing Roof Section 1

03-01/03-09

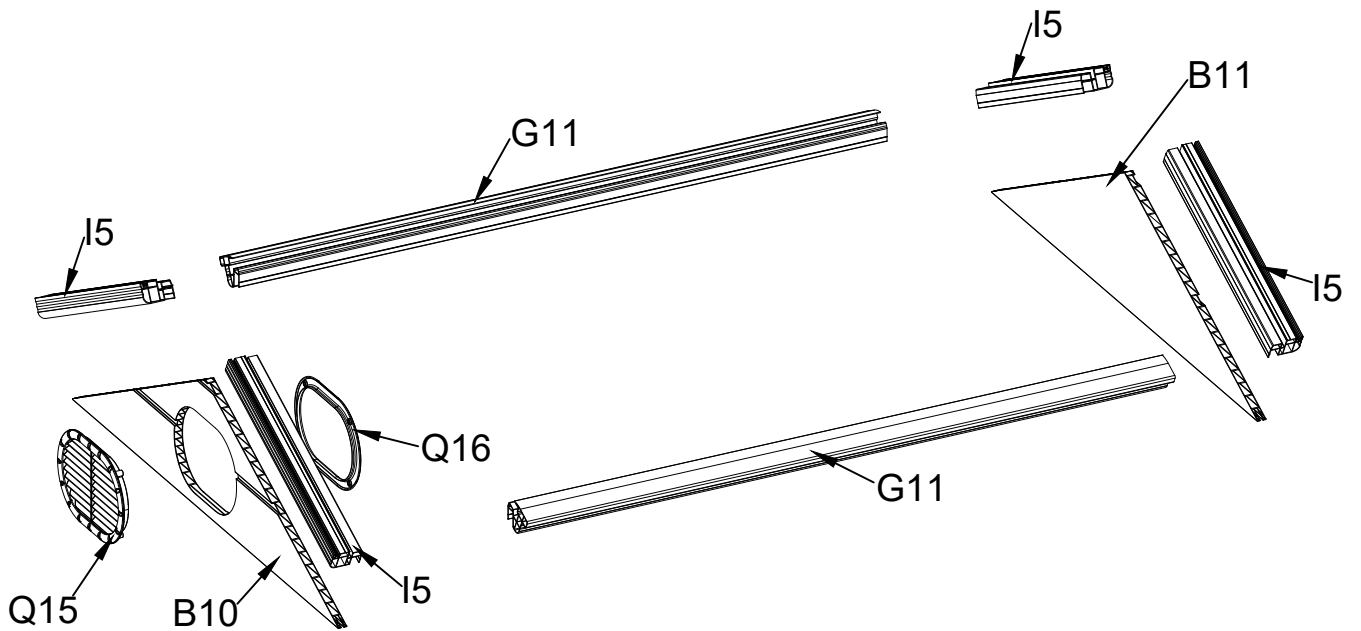

Step 04 Installing Roof Section 1  
Mount the metal skeleton

04-01/04-11

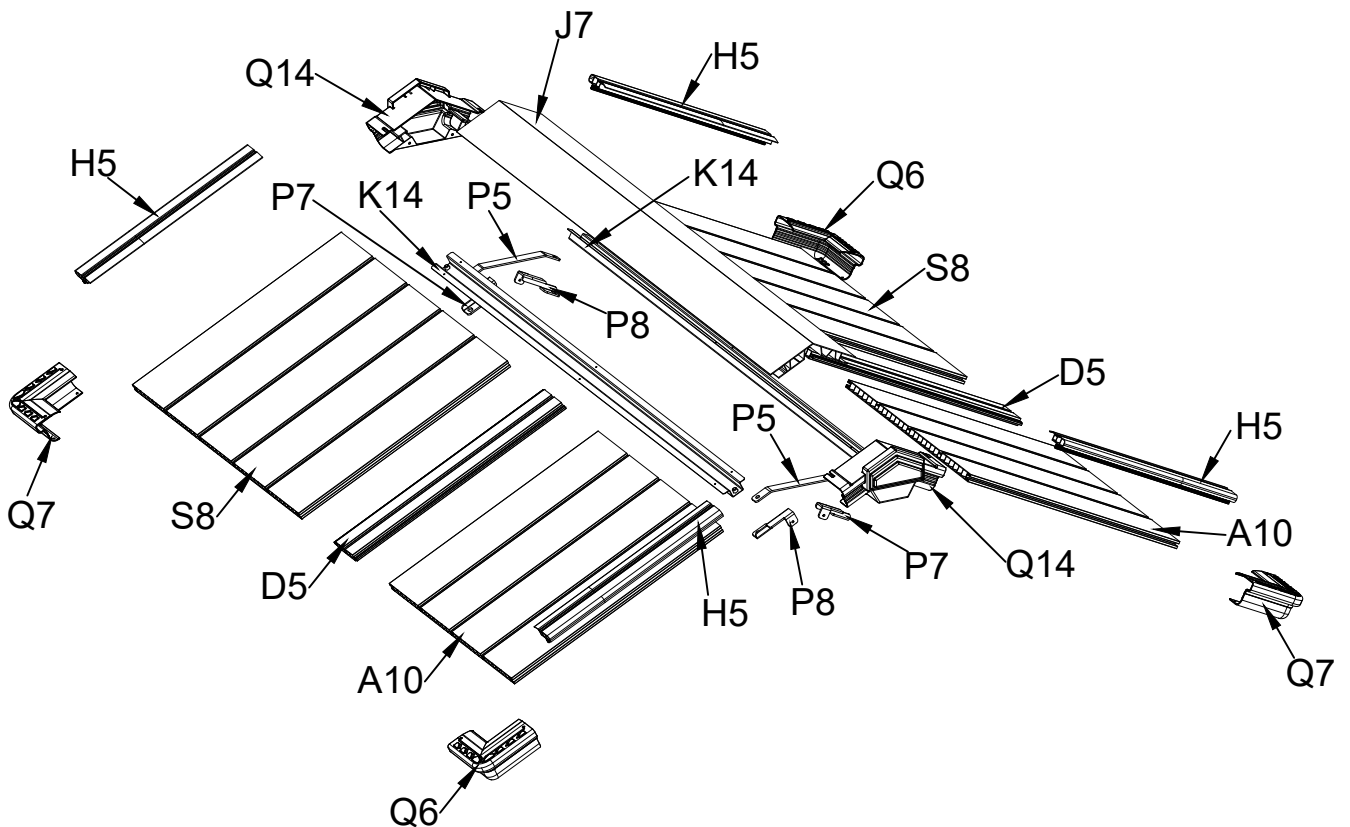

# Assembly Instruction Manual

## Table of Contents

Step 05 Fitting the Door

05-01/05-05

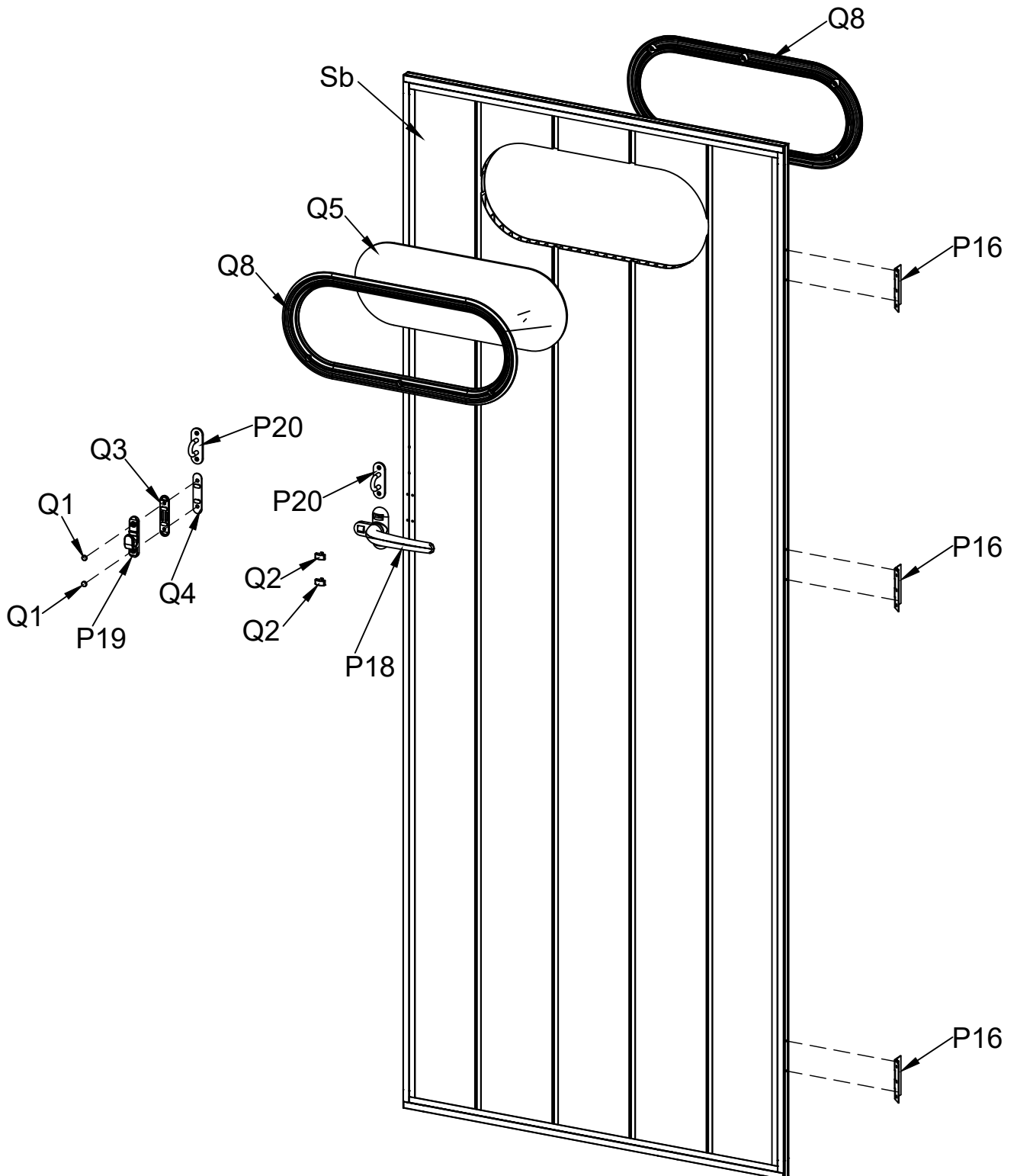

# Step 01 Packing List

A006

E3 1pc	L=61 F14 2pcs	L=866 F15 1pc	L=1142 F16 2pcs	L=914 R3 11pcs	L=914 R4 1pc
Q10 1pc	Q11 1pc	Q17 4pcs	ST4.0*18 Z5 33pcs	Za 1pc	Zb 1pc

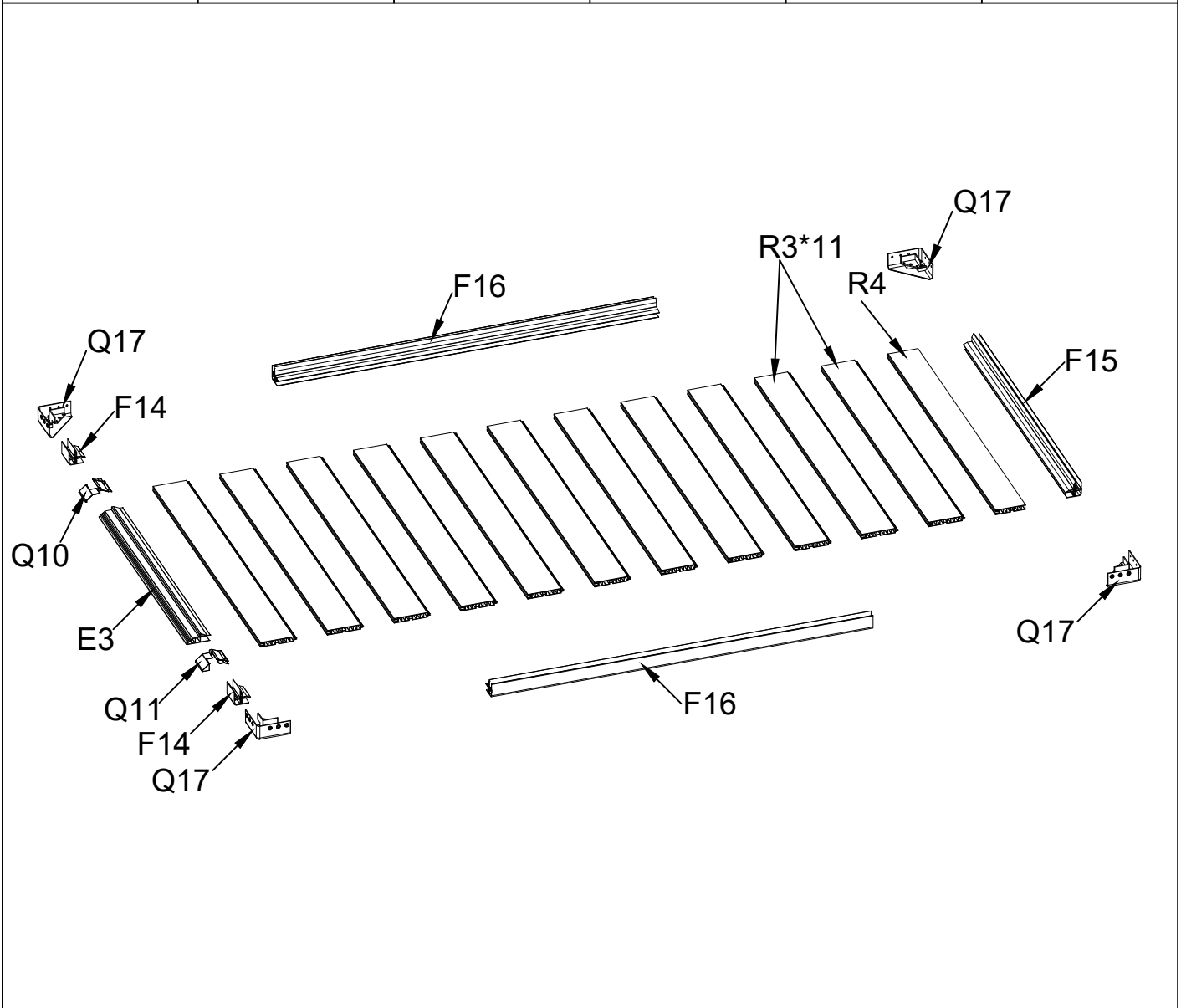

# ASSEMBLY INSTRUCTIONS

A006

01-01

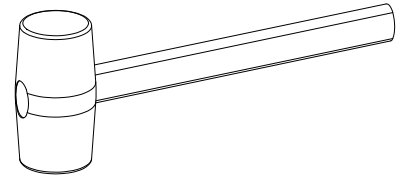
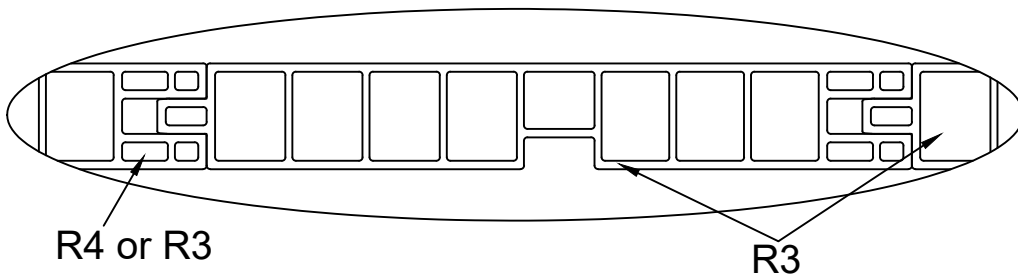
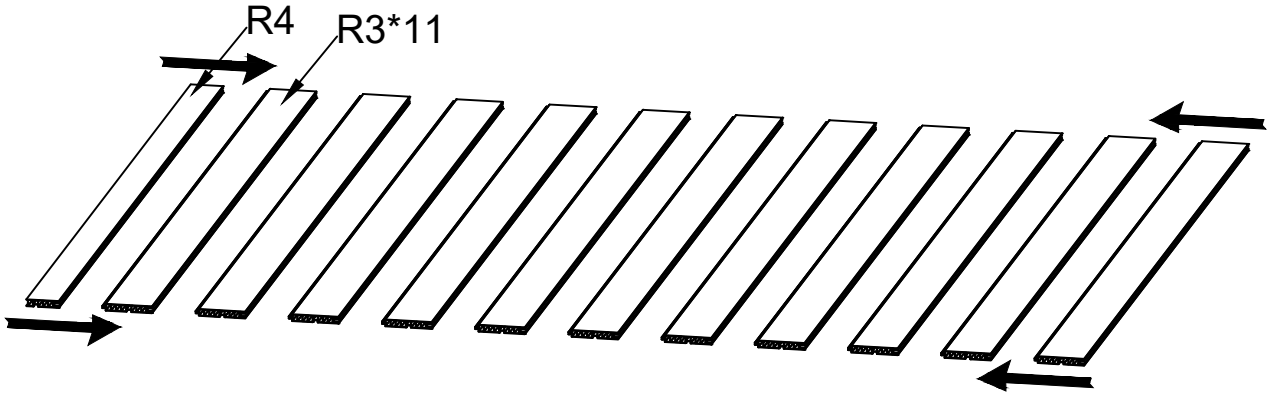

Please use the part "Za" to fasten each part "R3" and "R4"!

01-02

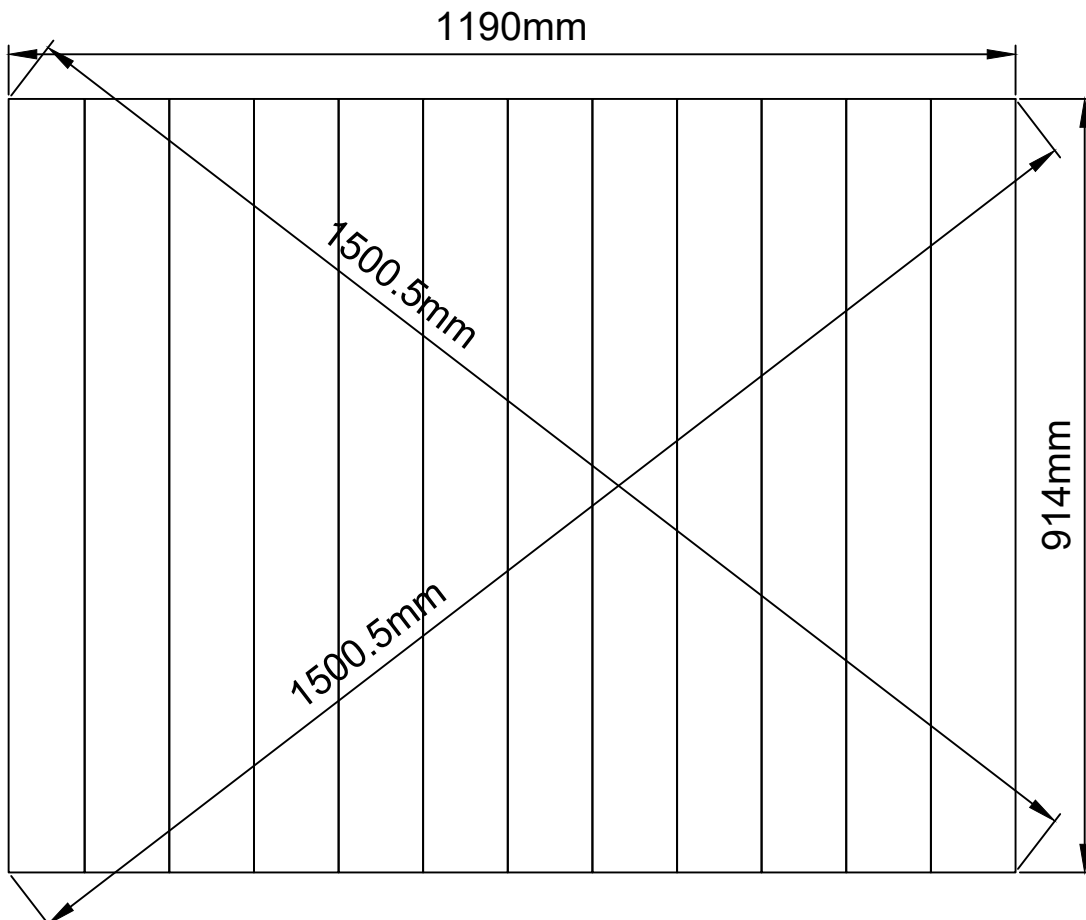

# ASSEMBLY INSTRUCTIONS

A006

01-03

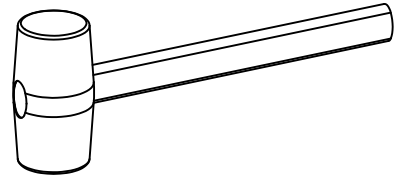
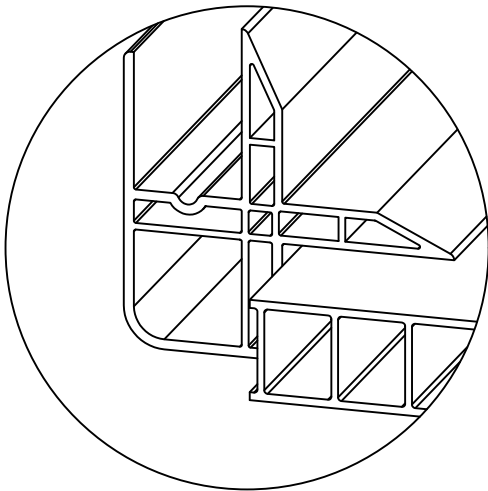
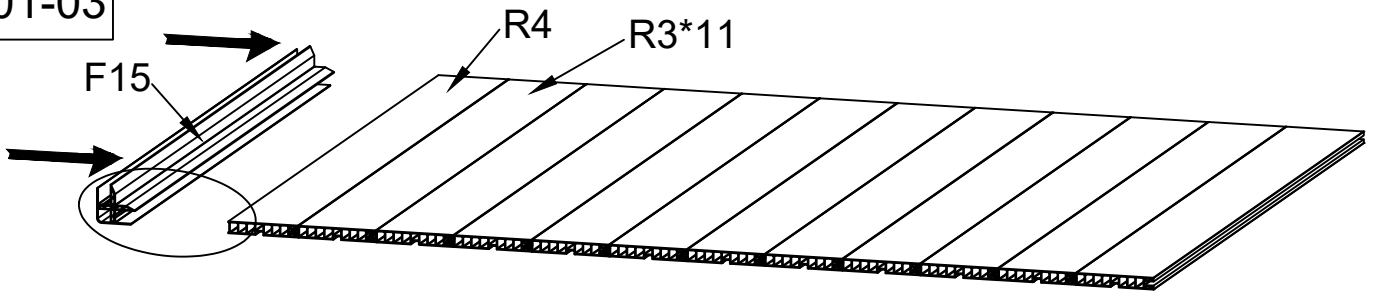

Please use the part "Za" to fasten each part "R4" and "F15"!

01-04

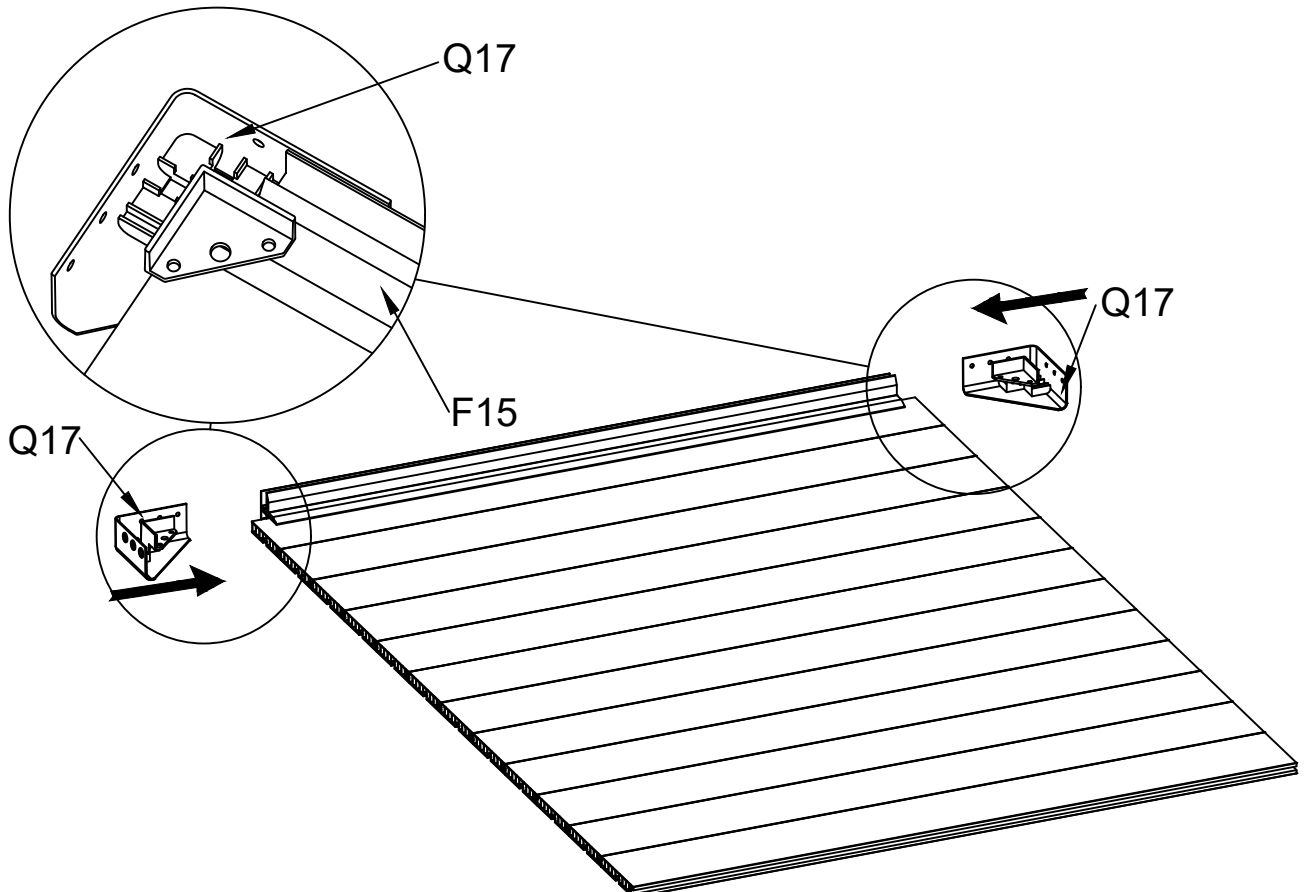

# ASSEMBLY INSTRUCTIONS

A006

01-05

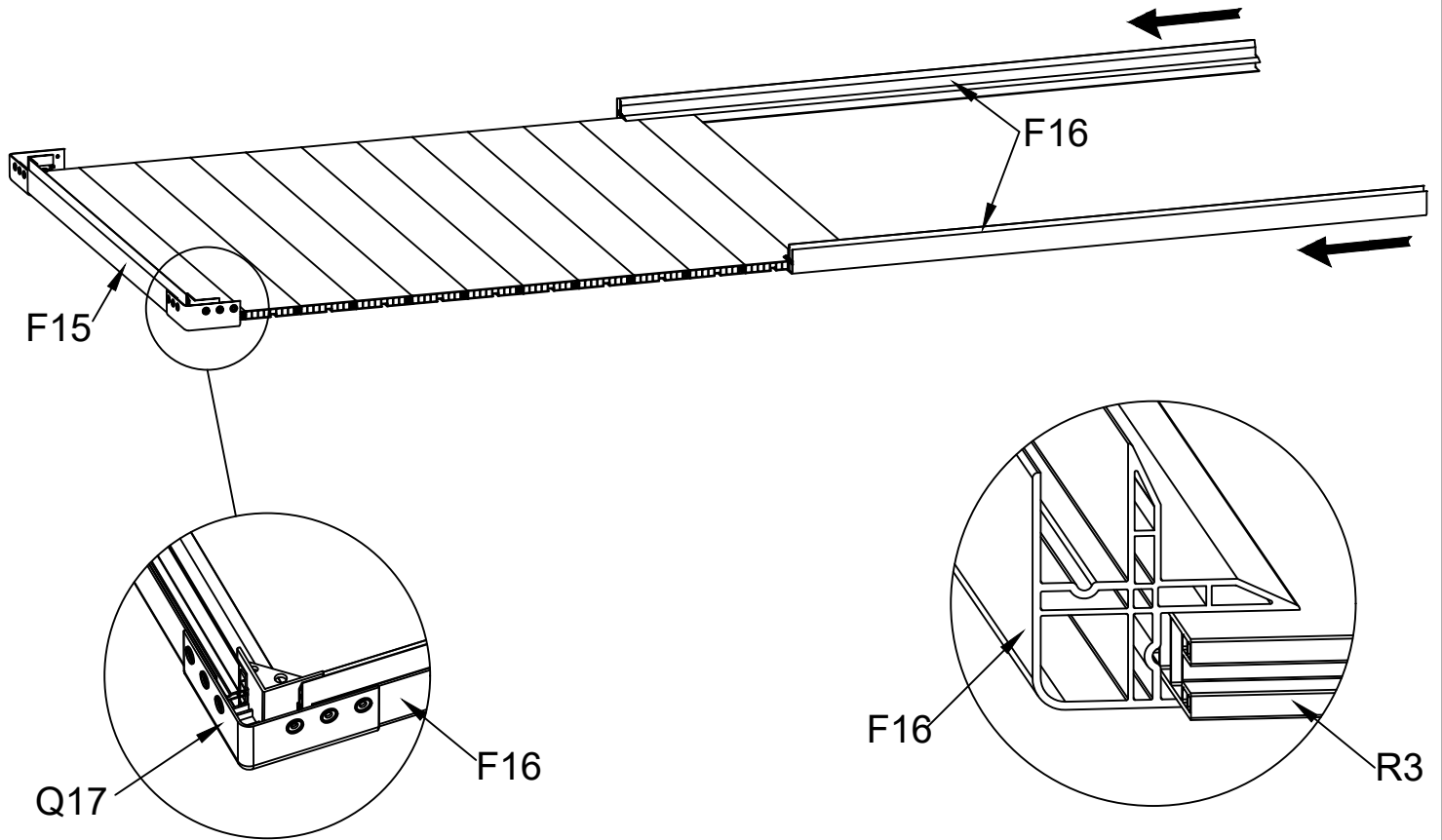

01-06

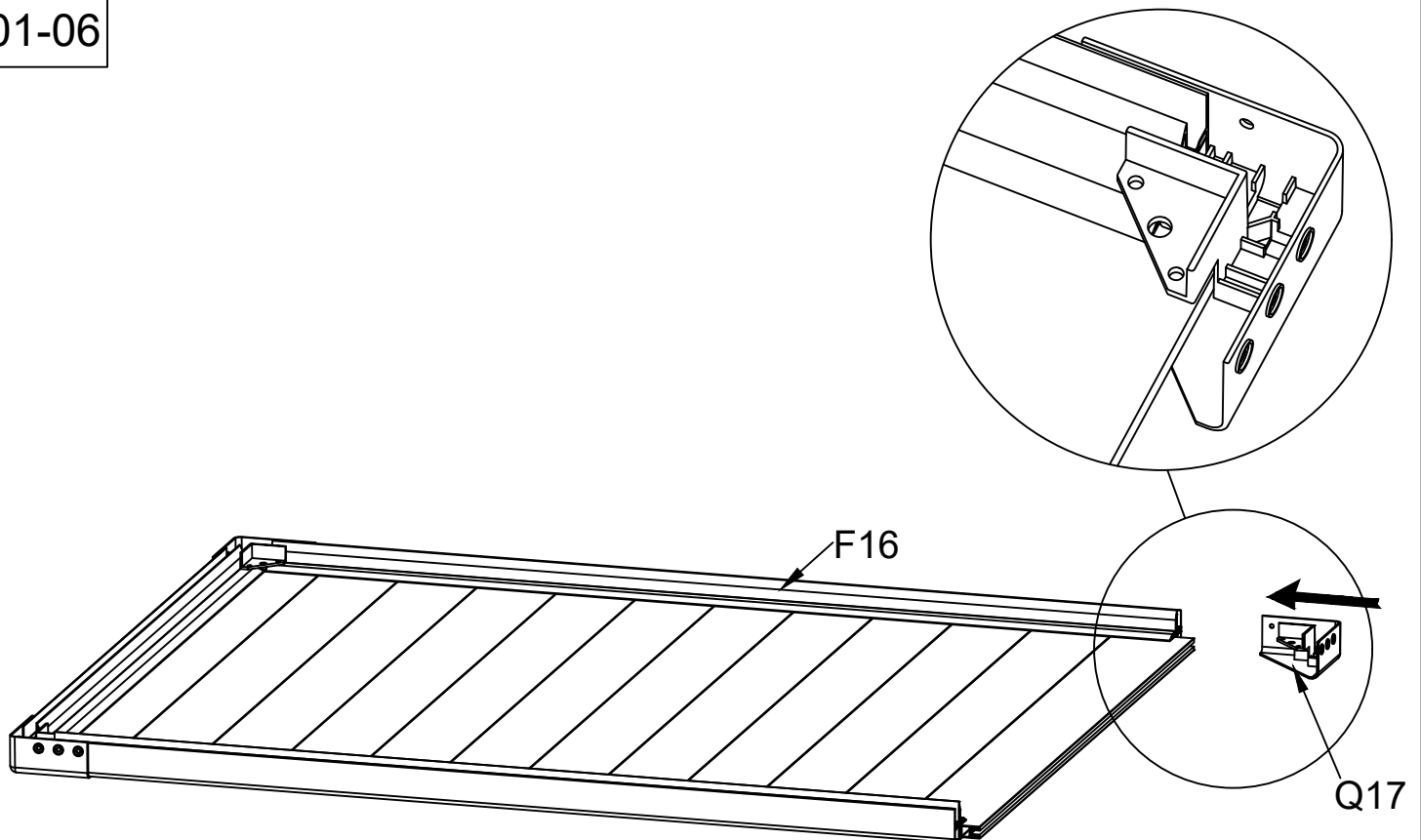

# ASSEMBLY INSTRUCTIONS

A006

01-07

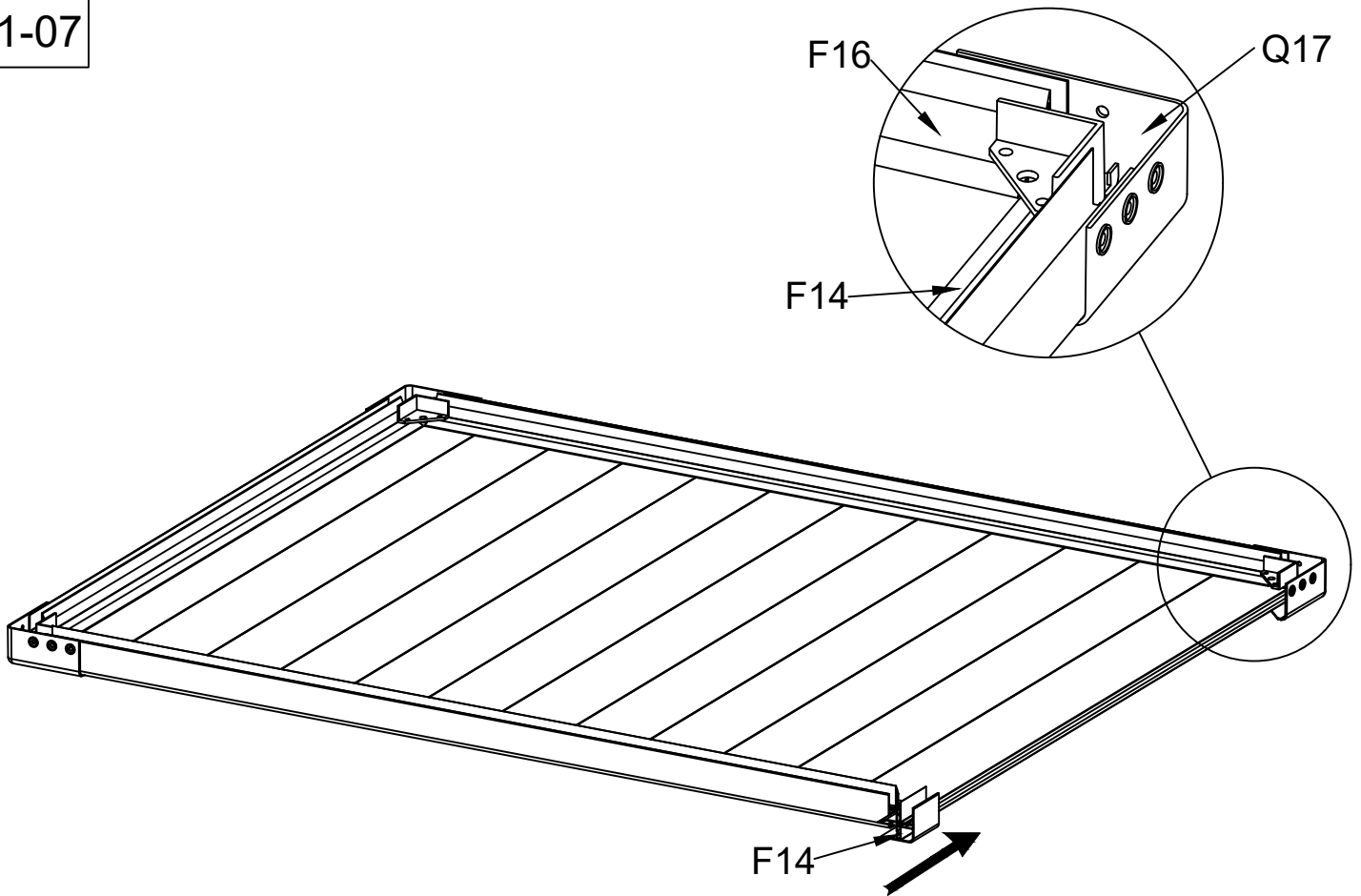

01-08

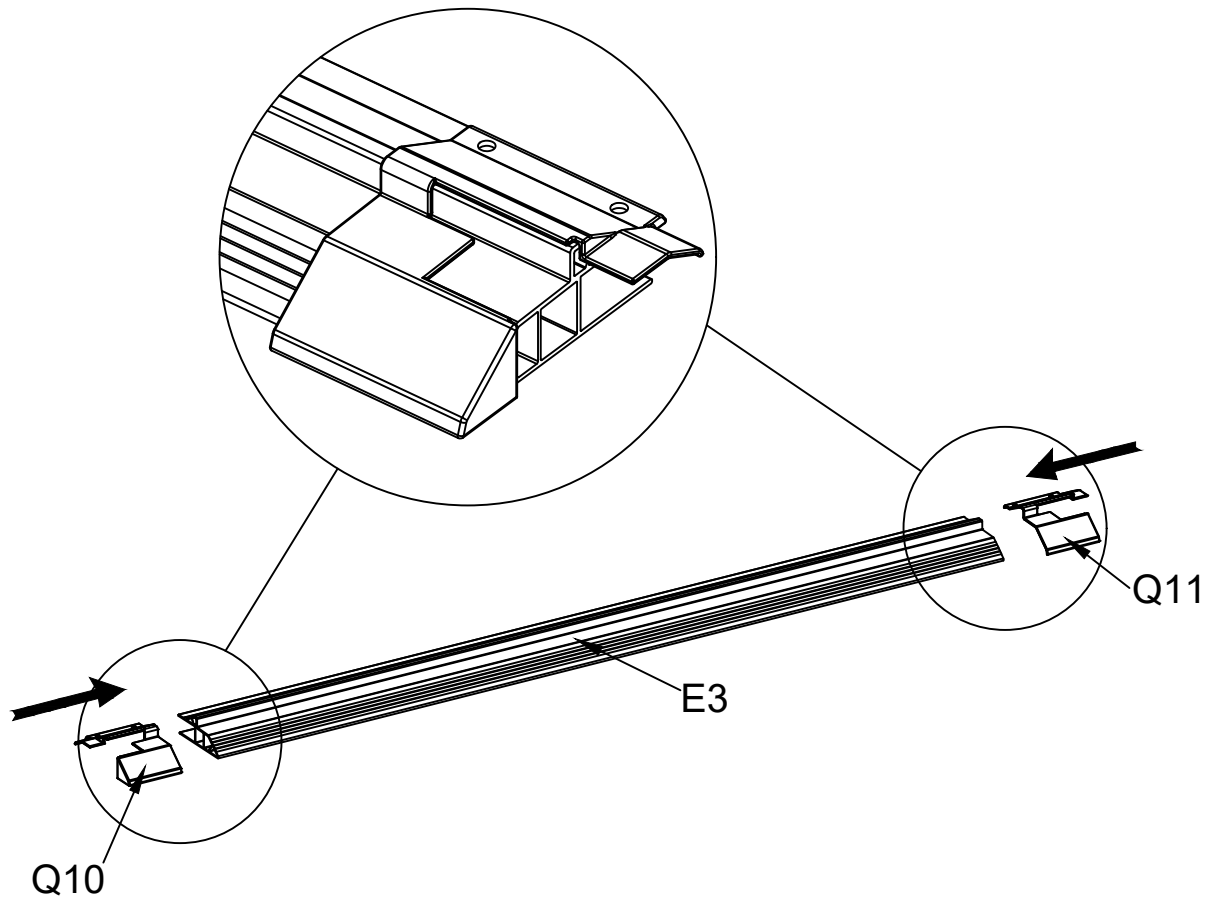

# ASSEMBLY INSTRUCTIONS

A006

01-09

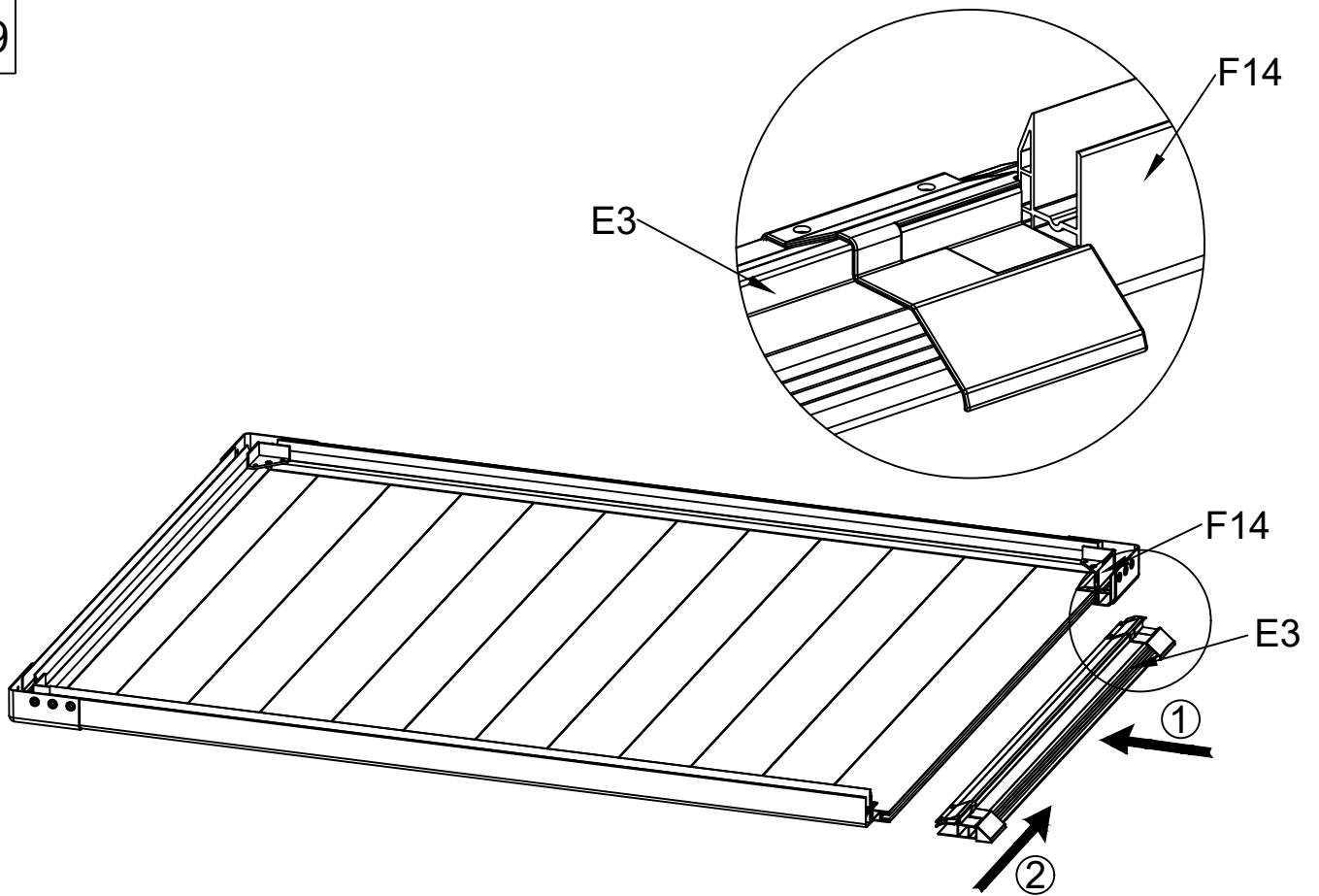

01-10

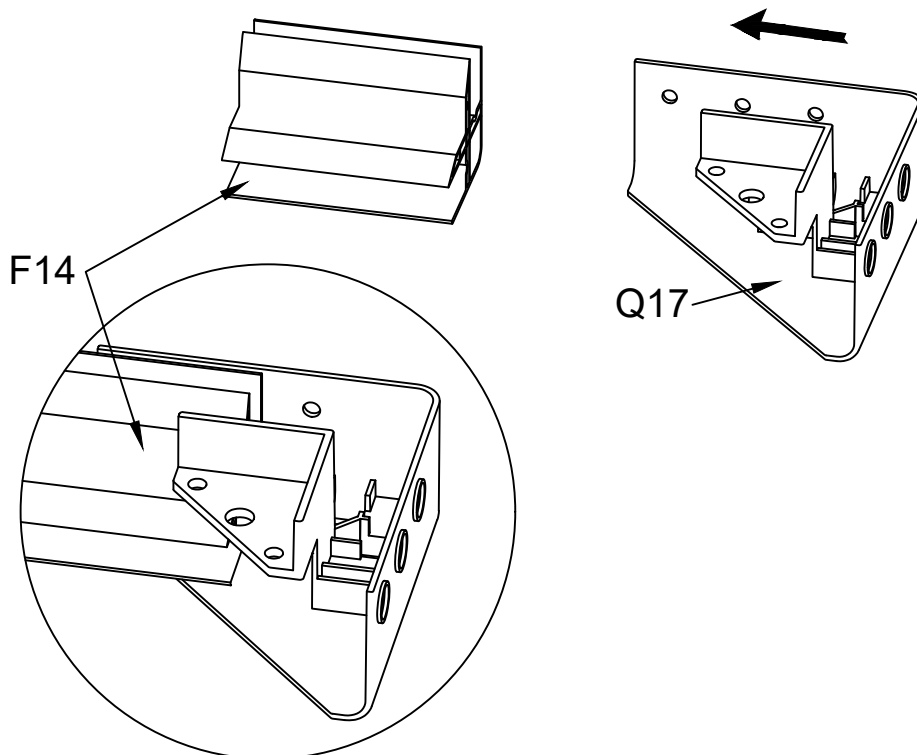

# ASSEMBLY INSTRUCTIONS

A006

01-11

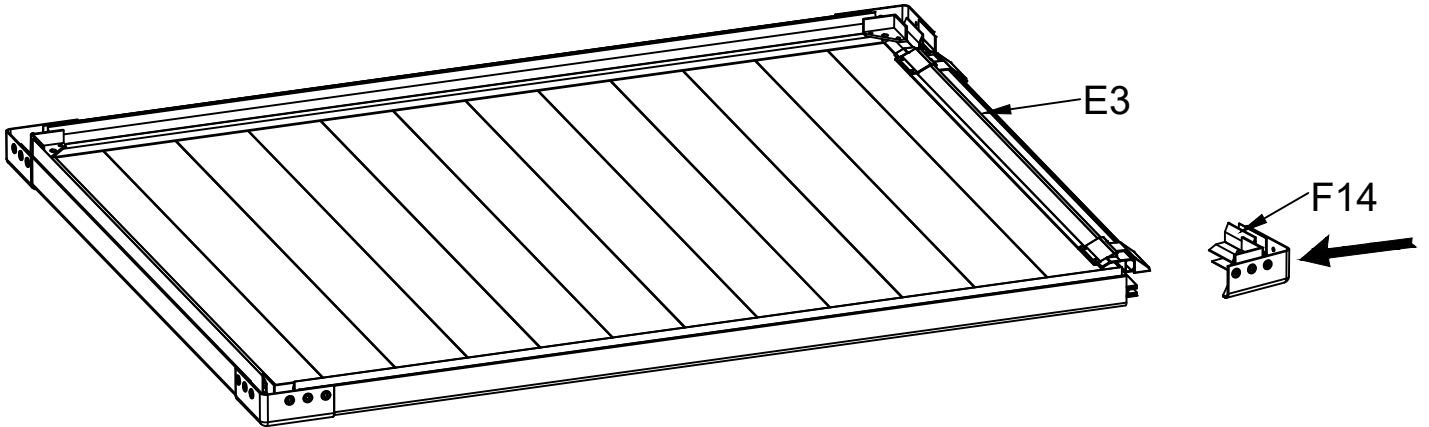

01-12

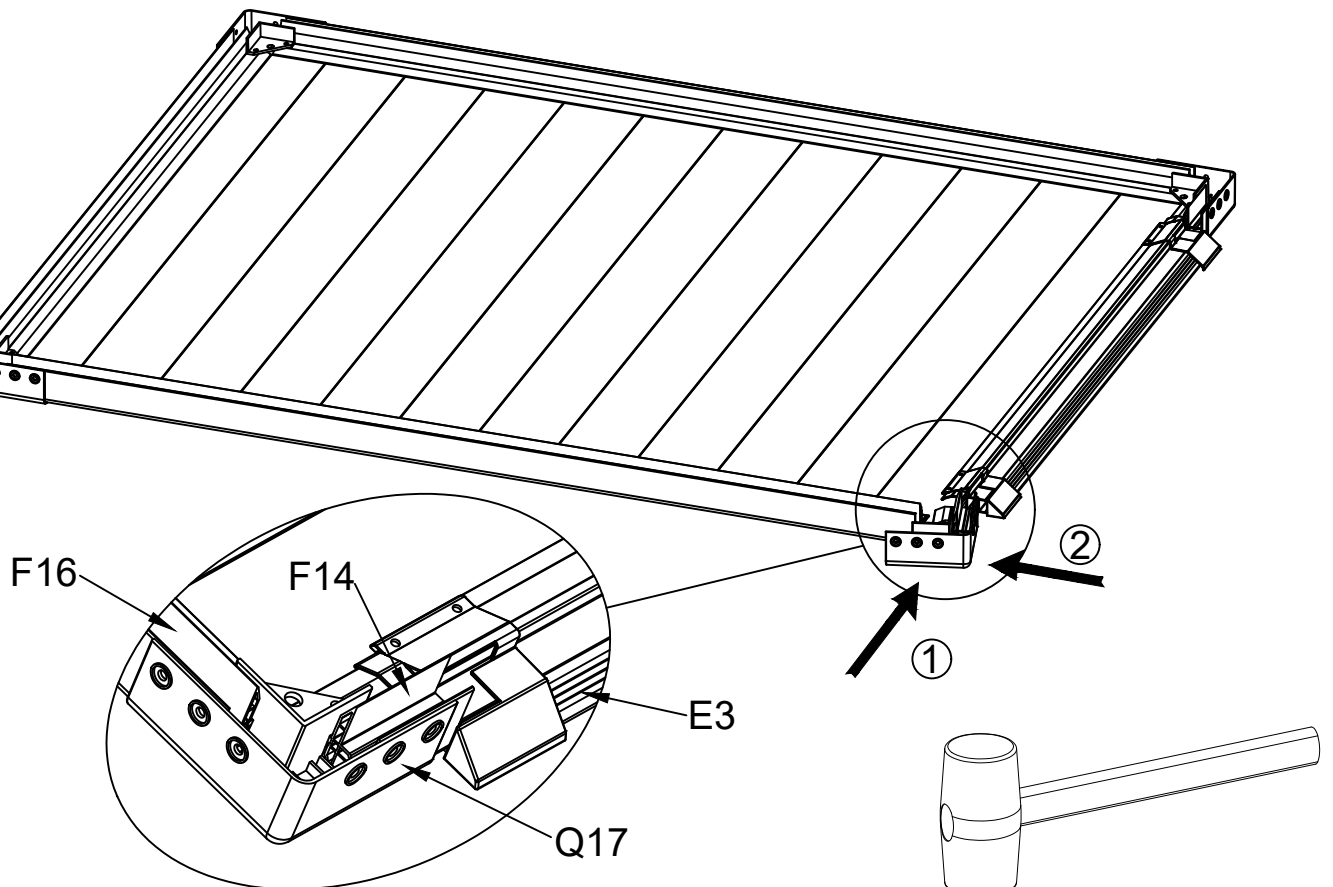

Please use the part "Za" to fasten each part "Q17" and "F16" and "F14"!

# ASSEMBLY INSTRUCTIONS

A006

01-13

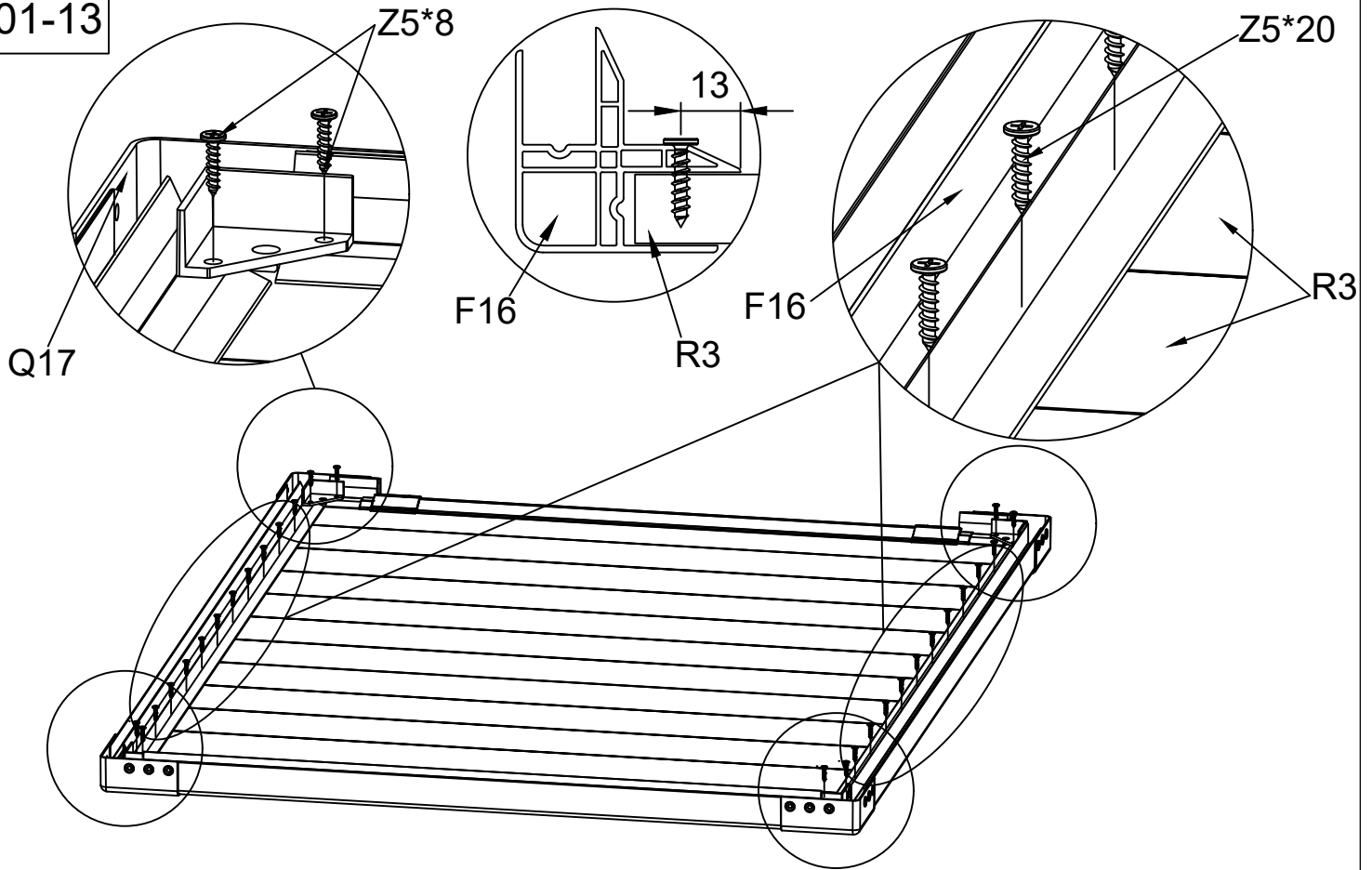



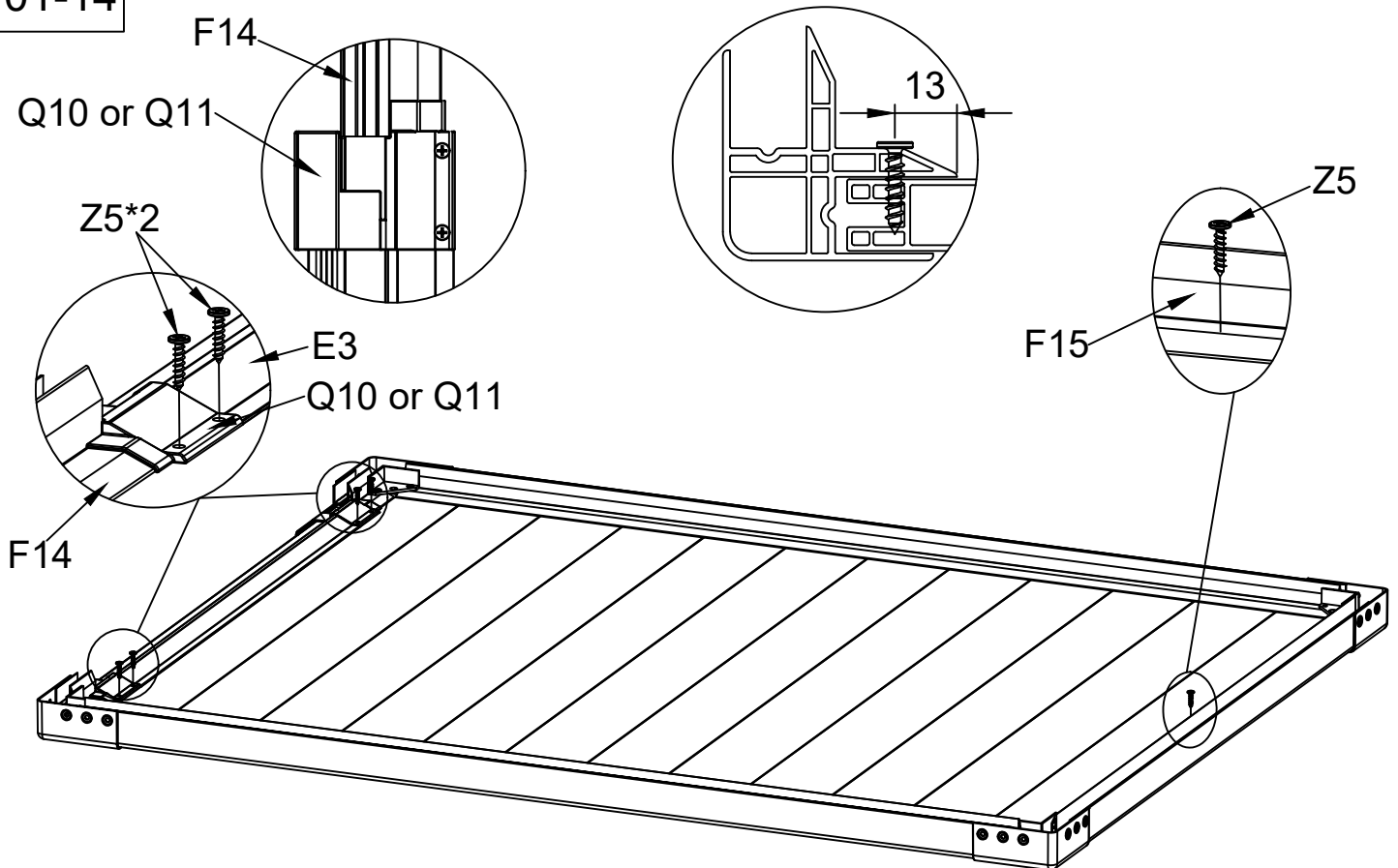





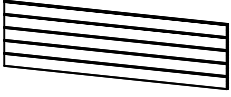

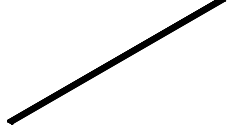

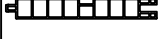
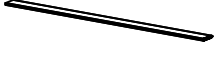



01-14

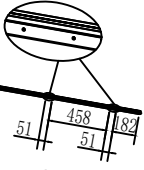

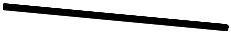
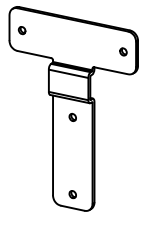
# Step 02 Packing List

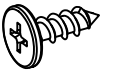
A006

 500*15*1775	 680*15*1775	  L=1775	  L=1793	  L=1775	  L=868
A2 2pcs	S1 3pcs	C1 4pcs	F1 4pcs	R5 4pcs	U1 1pc
  43*22*868	  40*20.2*1765	  40*20.2*1765		 ST4.0*18	 ST4.0*12
M9 1pc	O3 1pc	O4 1pc	P9 2pcs	Z5 50pcs	Z6 35pcs
					
Za 1pc	Zb 1pc				

# ASSEMBLY INSTRUCTIONS

A006

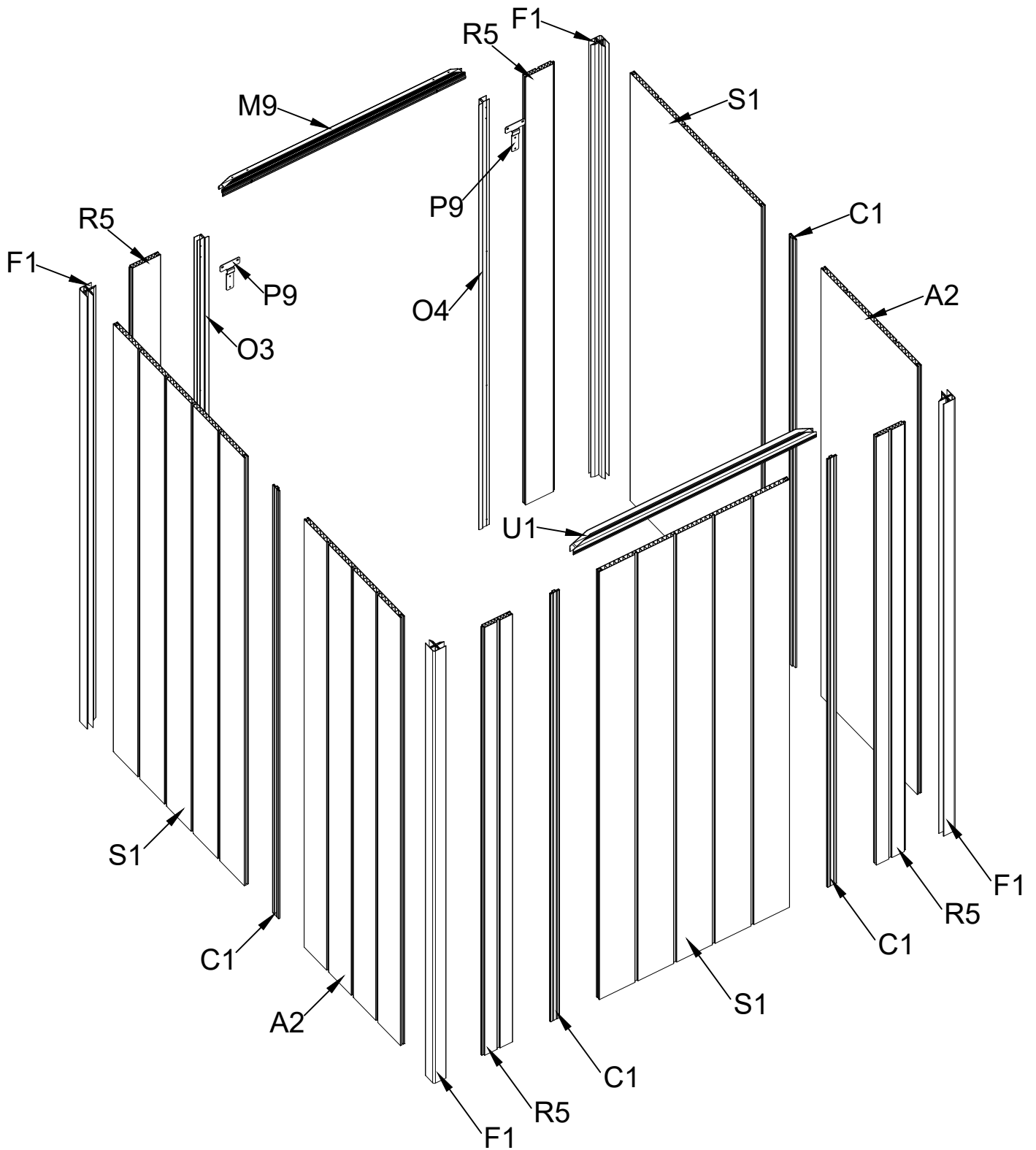

# ASSEMBLY INSTRUCTIONS

A006

02-01

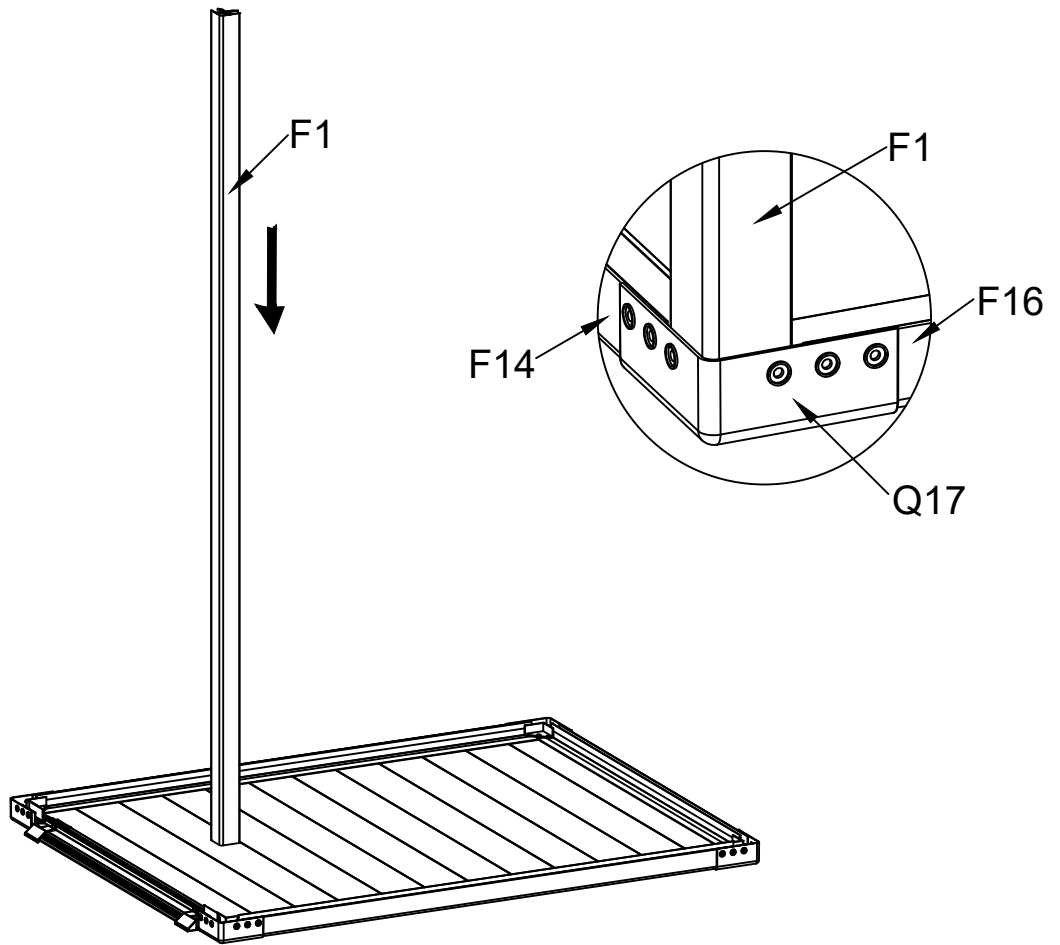

02-02

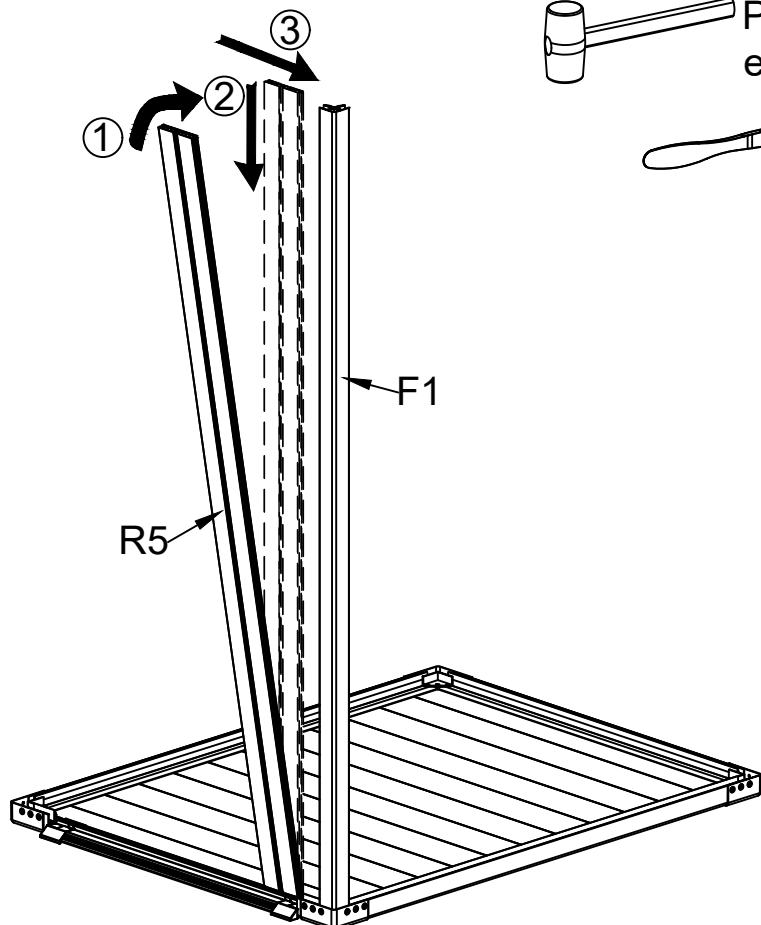

Please use the part "Za" to fasten each part "R5" and "F1"!



If any difficult during the assemble, pls use Part "Zb" for assistance!

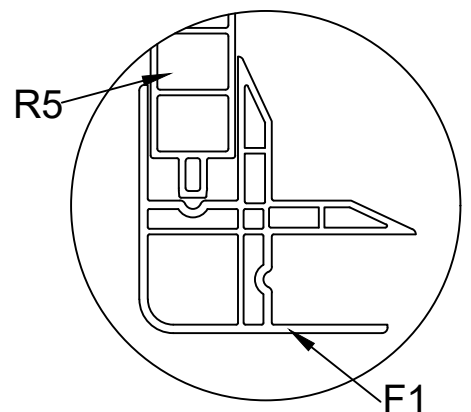

# ASSEMBLY INSTRUCTIONS

A006

02-03

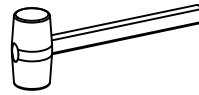
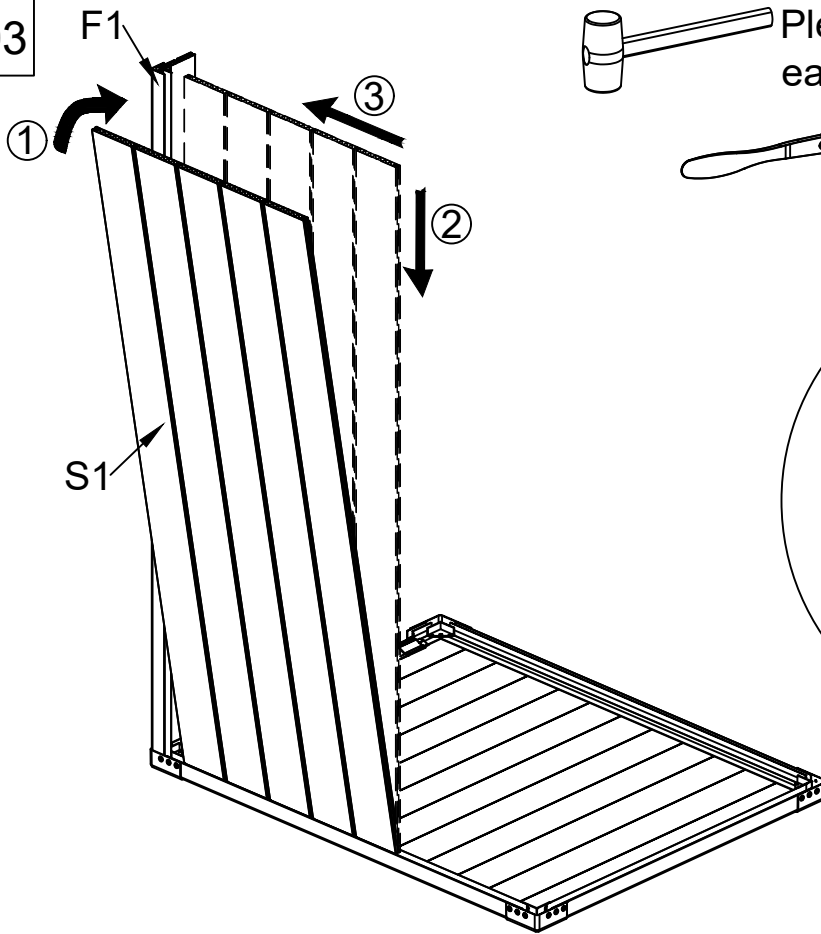

Please use the part "Za" to fasten each part "S1" and "F1"!



If any difficult during the assemble, pls use Part "Zb" for assistance!

02-04

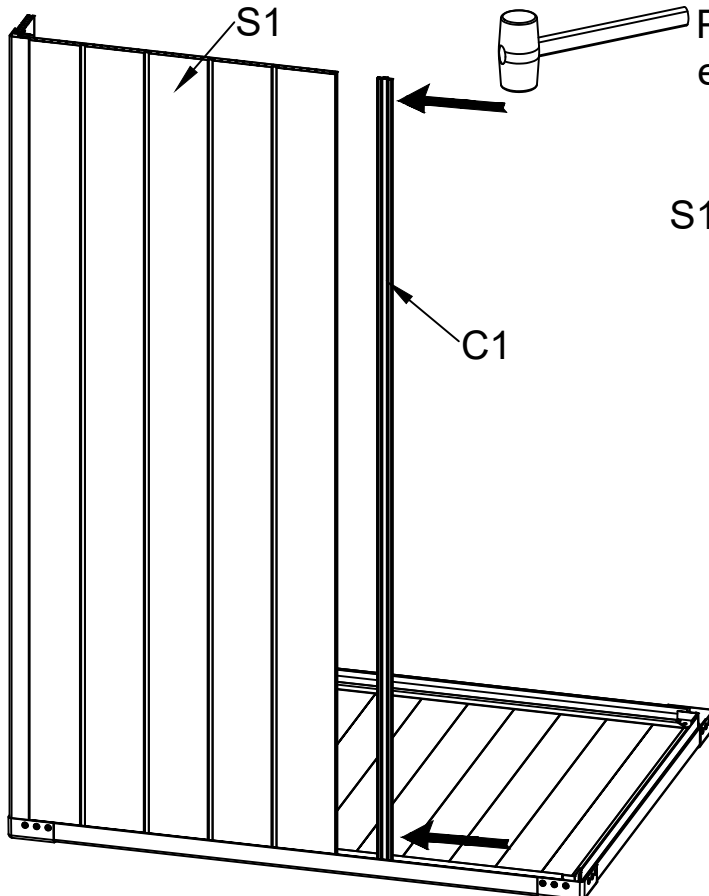

Please use the part "Za" to fasten each part "S1" and "C1"!

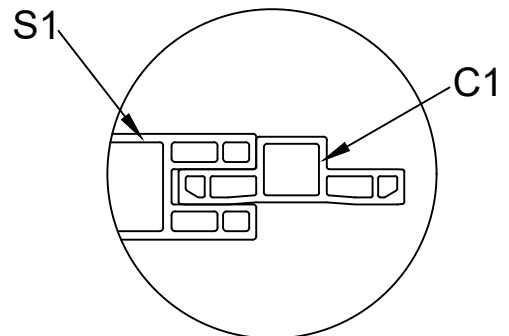

# ASSEMBLY INSTRUCTIONS

A006

02-05

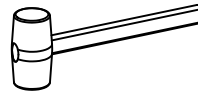
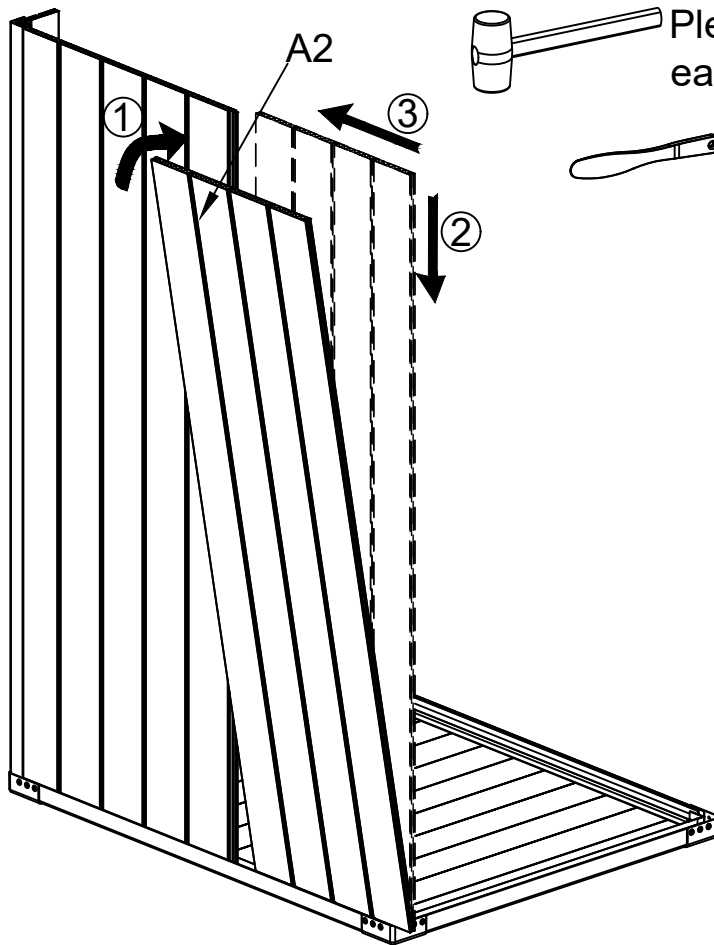

Please use the part "Za" to fasten each part "A2" and "C1"!



If any difficult during the assemble, pls use Part "Zb" for assistance!

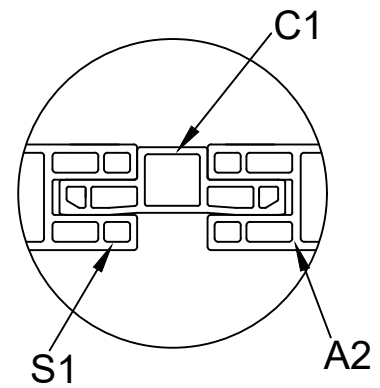

02-06

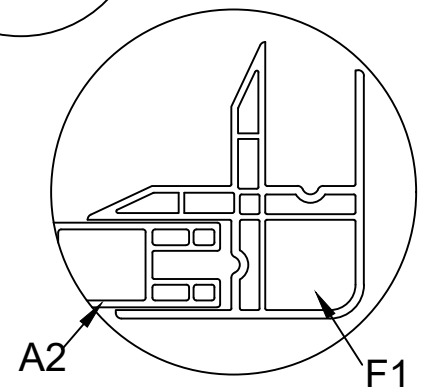
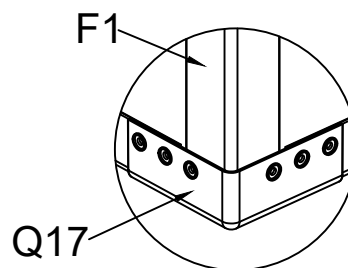
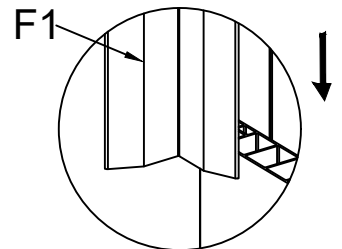
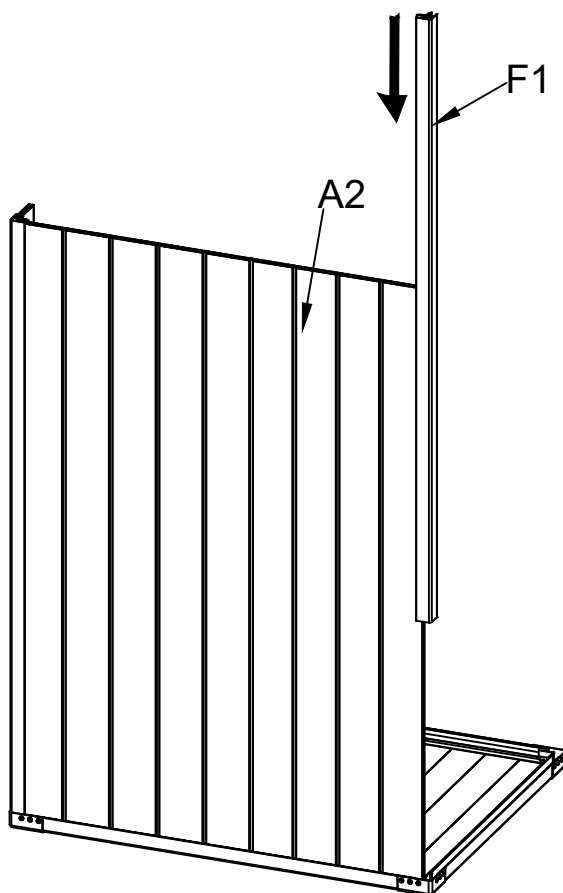

If any difficult during the assemble, pls use Part "Zb" for assistance!

# ASSEMBLY INSTRUCTIONS

A006

02-07

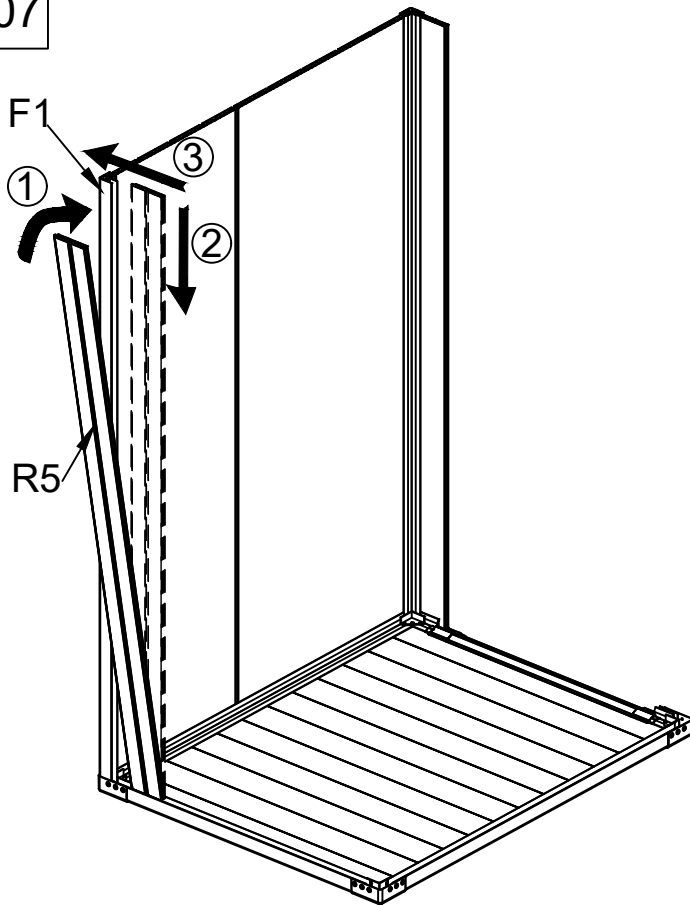

Please use the part "Za" to fasten each part "F1" and "R5"!



If any difficult during the assemble, pls use Part "Zb" for assistance!

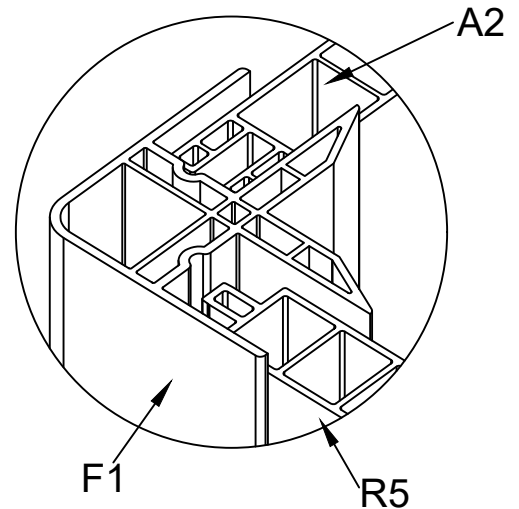

02-08

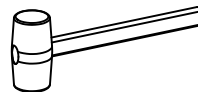
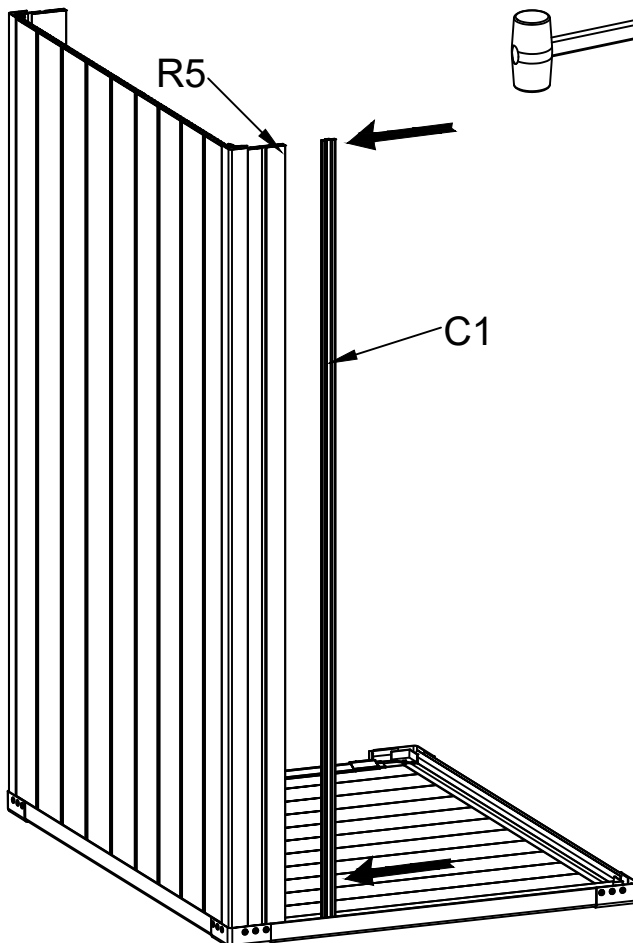

Please use the part "Za" to fasten each part "R5" and "C1"!

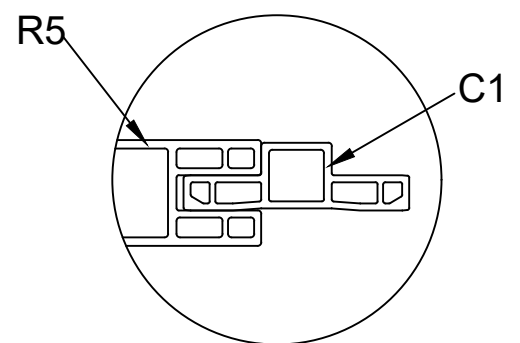

# ASSEMBLY INSTRUCTIONS

A006

02-09

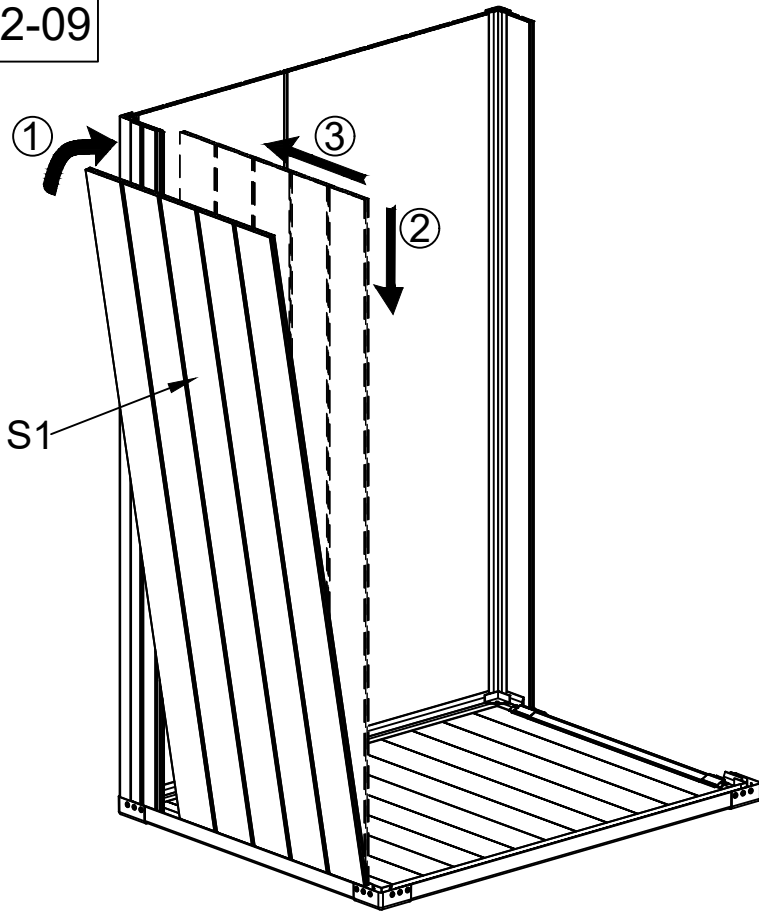

Please use the part "Za" to fasten each part "S1" and "C1"!



If any difficult during the assemble, pls use Part "Zb" for assistance!

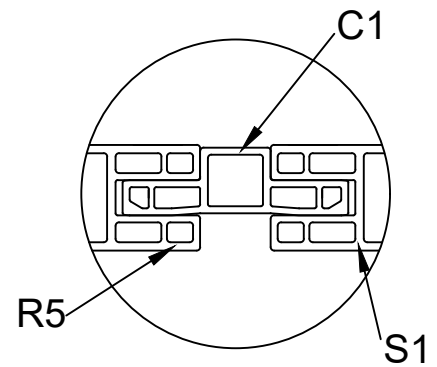

02-10

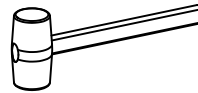
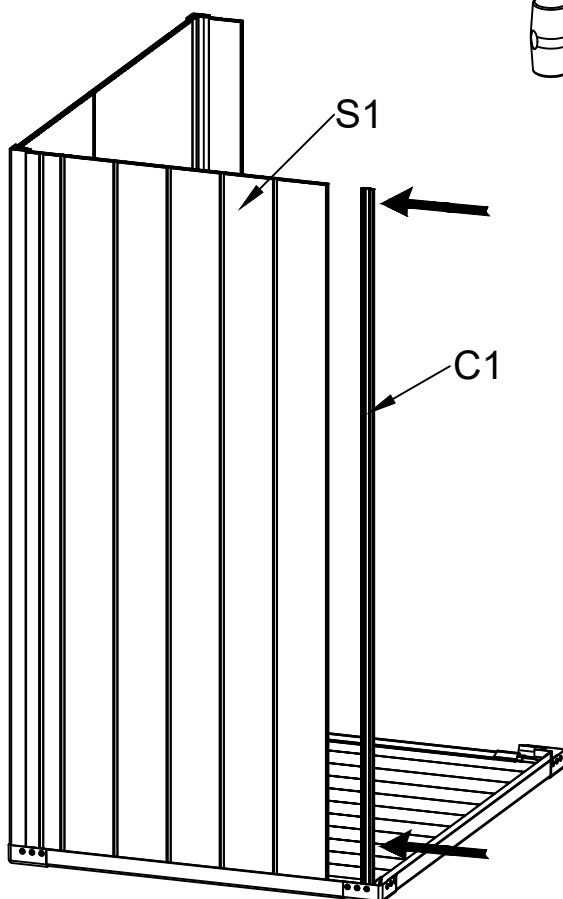

Please use the part "Za" to fasten each part "S1" and "C1"!

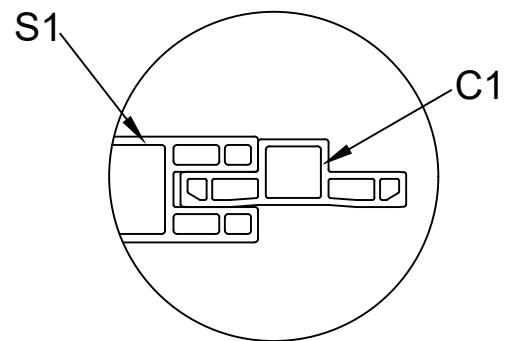

# ASSEMBLY INSTRUCTIONS

A006

02-11

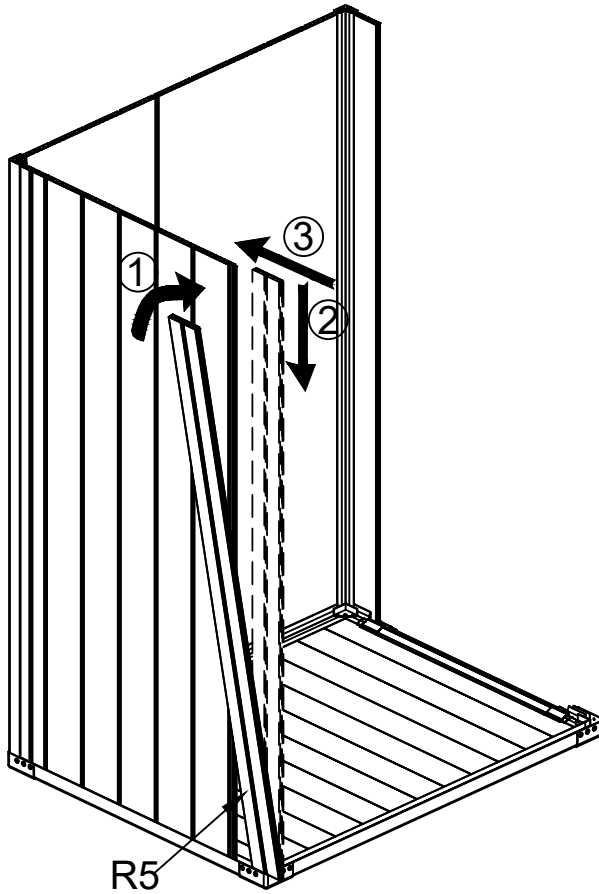

Please use the part "Za" to fasten each part "R5" and "C1"!



If any difficult during the assemble, pls use Part "Zb" for assistance!

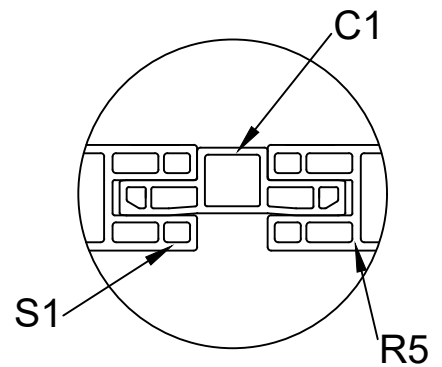

02-12

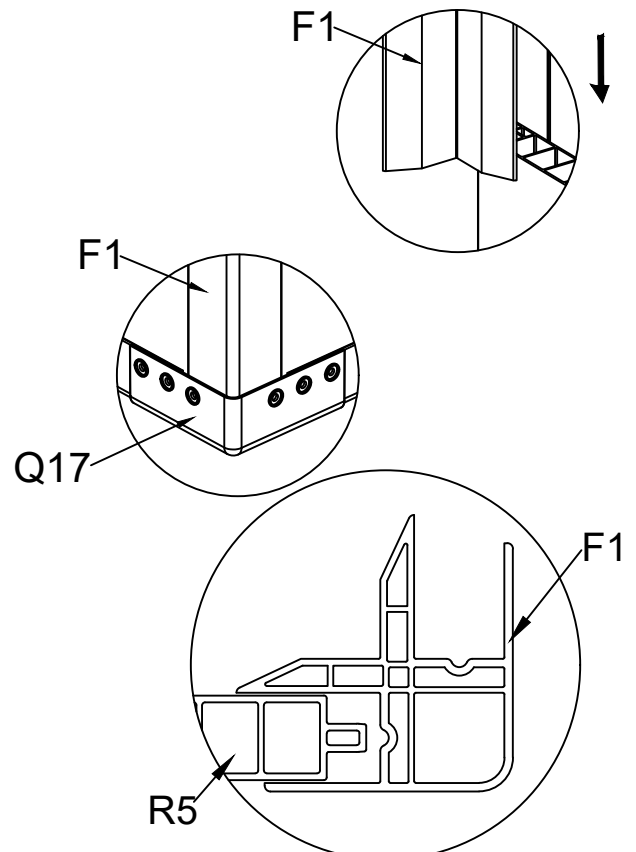
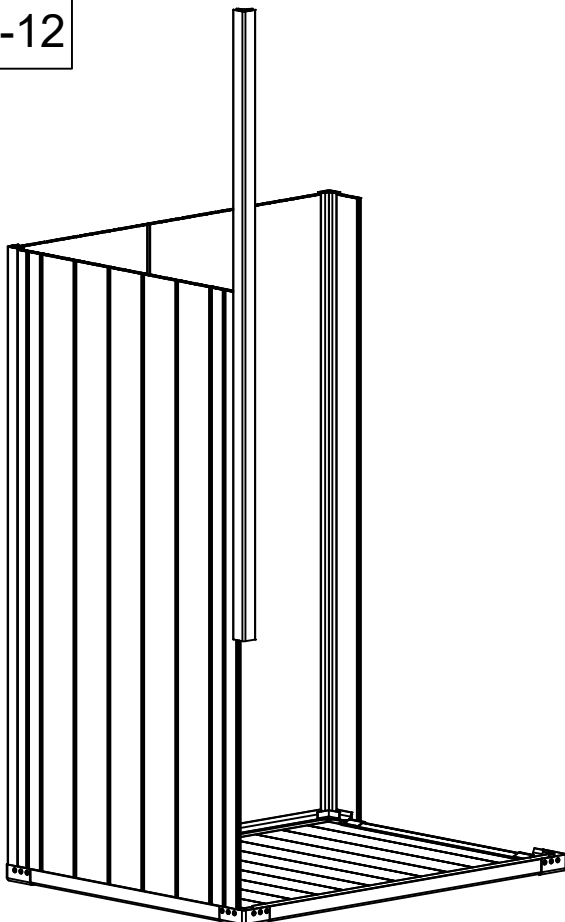

If any difficult during the assemble, pls use Part "Zb" for assistance!

# ASSEMBLY INSTRUCTIONS

A006

02-13

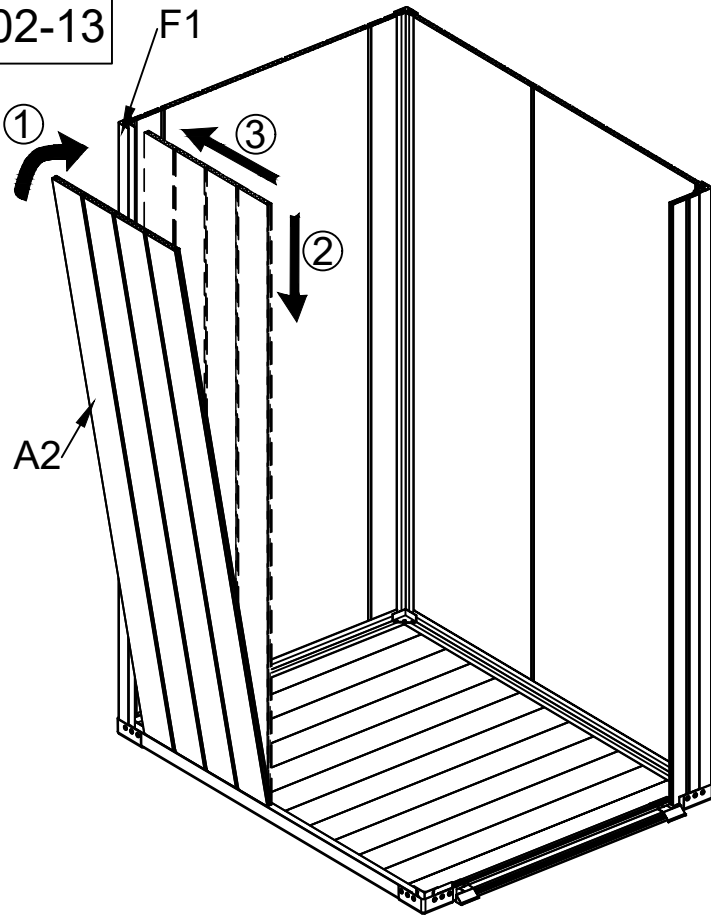

Please use the part "Za" to fasten each part "F1" and "A2"!



If any difficult during the assemble, pls use Part "Zb" for assistance!

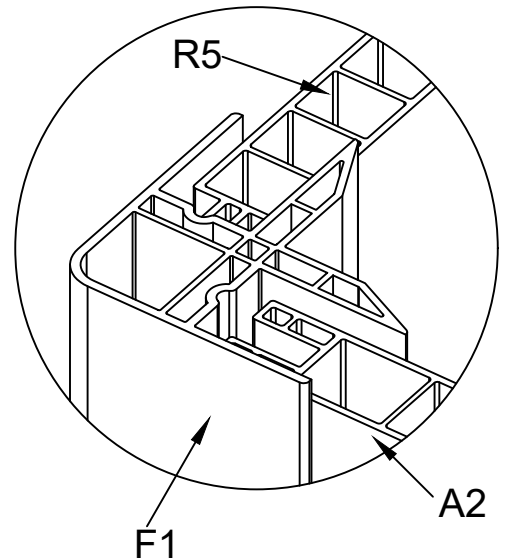

02-14

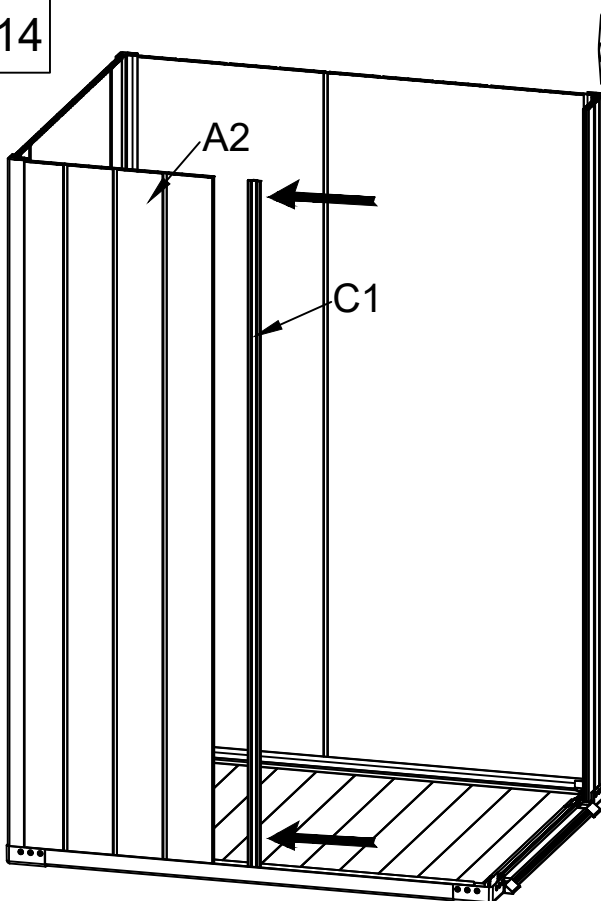

Please use the part "Za" to fasten each part "A2" and "C1"!

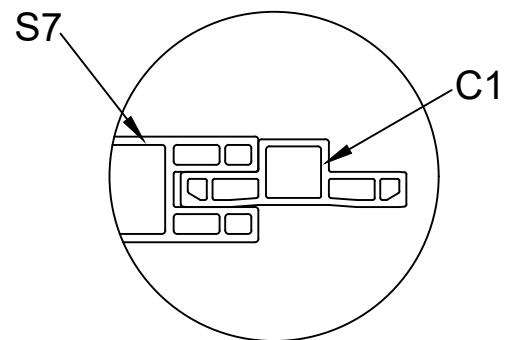

# ASSEMBLY INSTRUCTIONS

A006

02-15

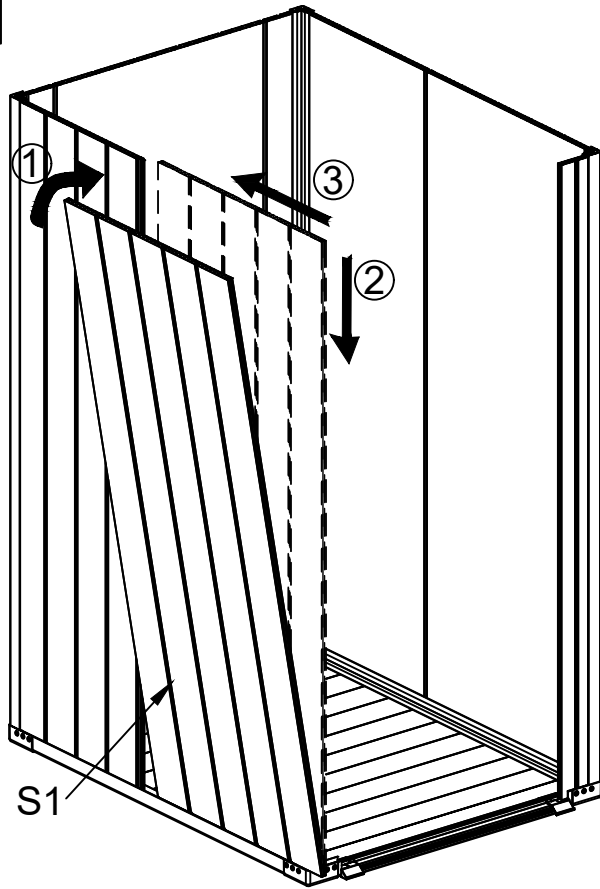

Please use the part "Za" to fasten each part "S1" and "C1"!



If any difficult during the assemble, pls use Part "Zb" for assistance!

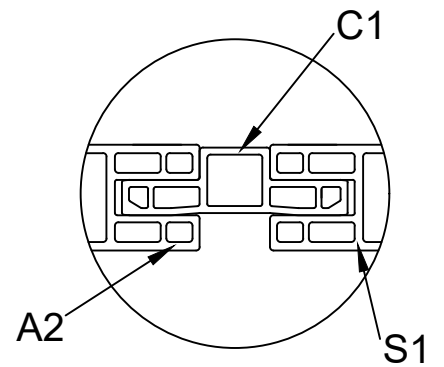

02-16

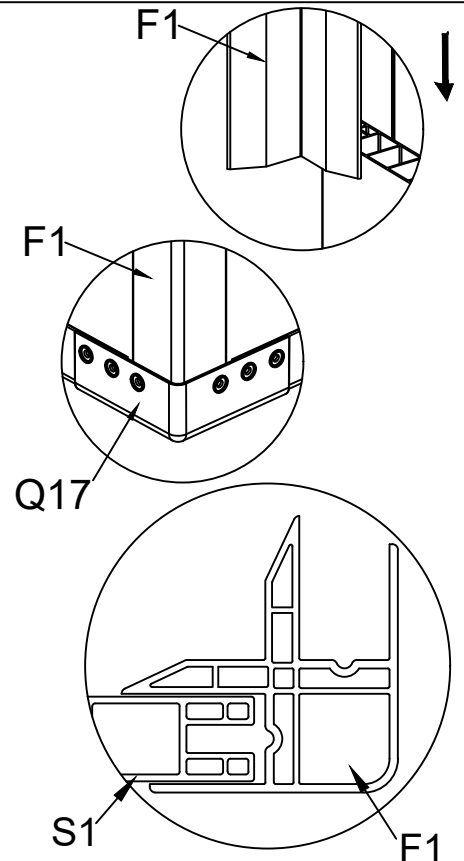
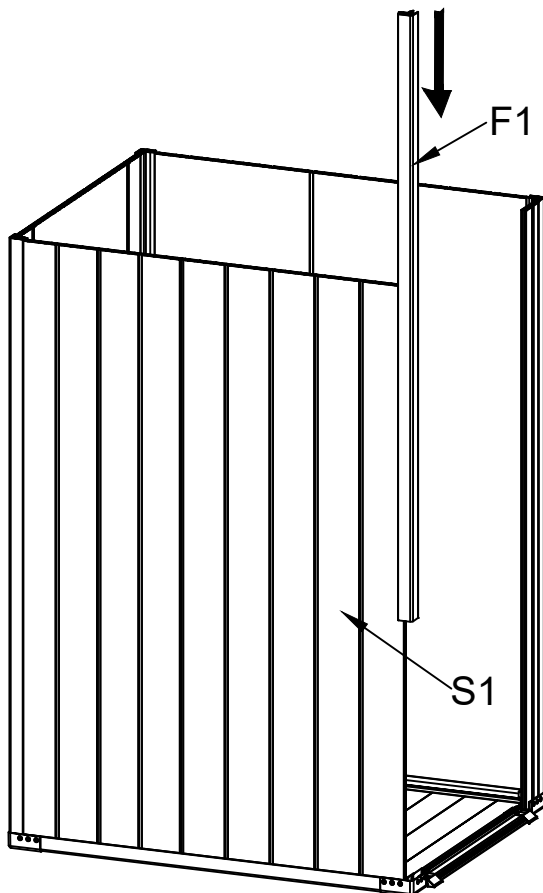

If any difficult during the assemble, pls use Part "Zb" for assistance!

# ASSEMBLY INSTRUCTIONS

A006

02-17

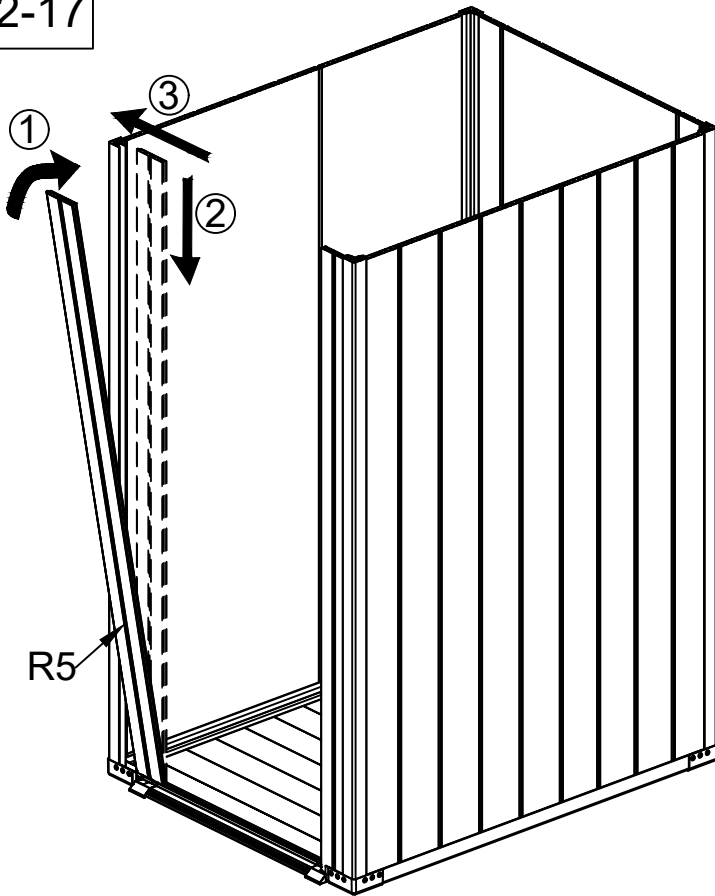

Please use the part "Za" to fasten each part "F1" and "R5"!



If any difficult during the assemble, pls use Part "Zb" for assistance!

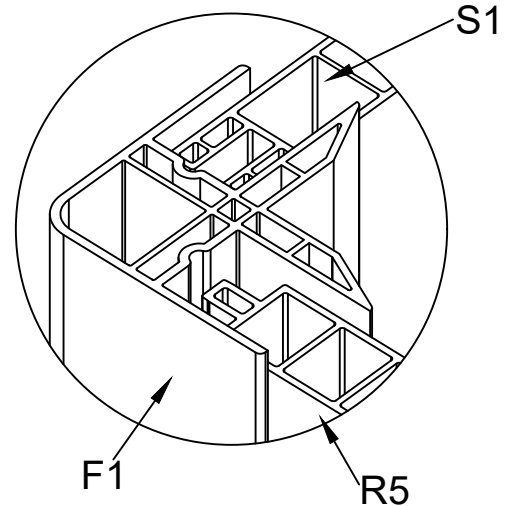

02-18

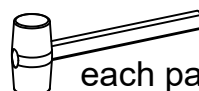
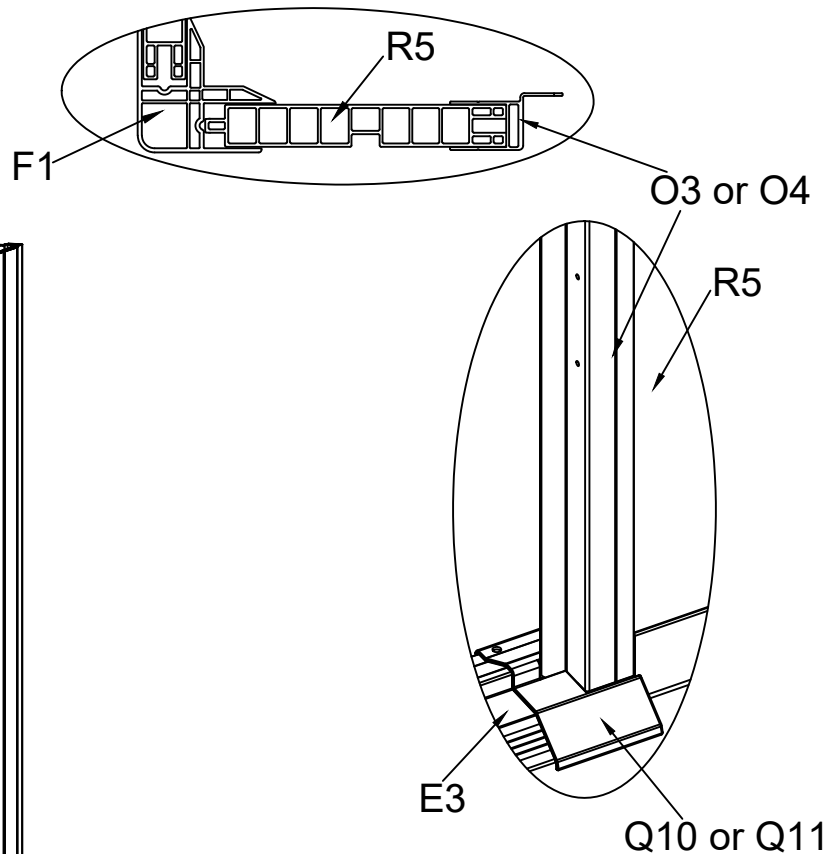
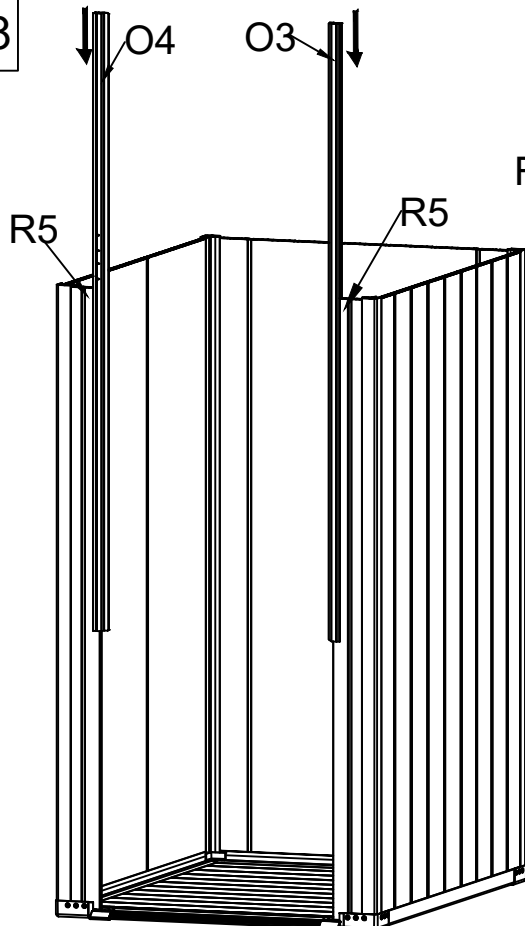

Please use the part "Za" to fasten each part "F1" and "R5" and "O3" or "O4"!

# ASSEMBLY INSTRUCTIONS

A006

02-19

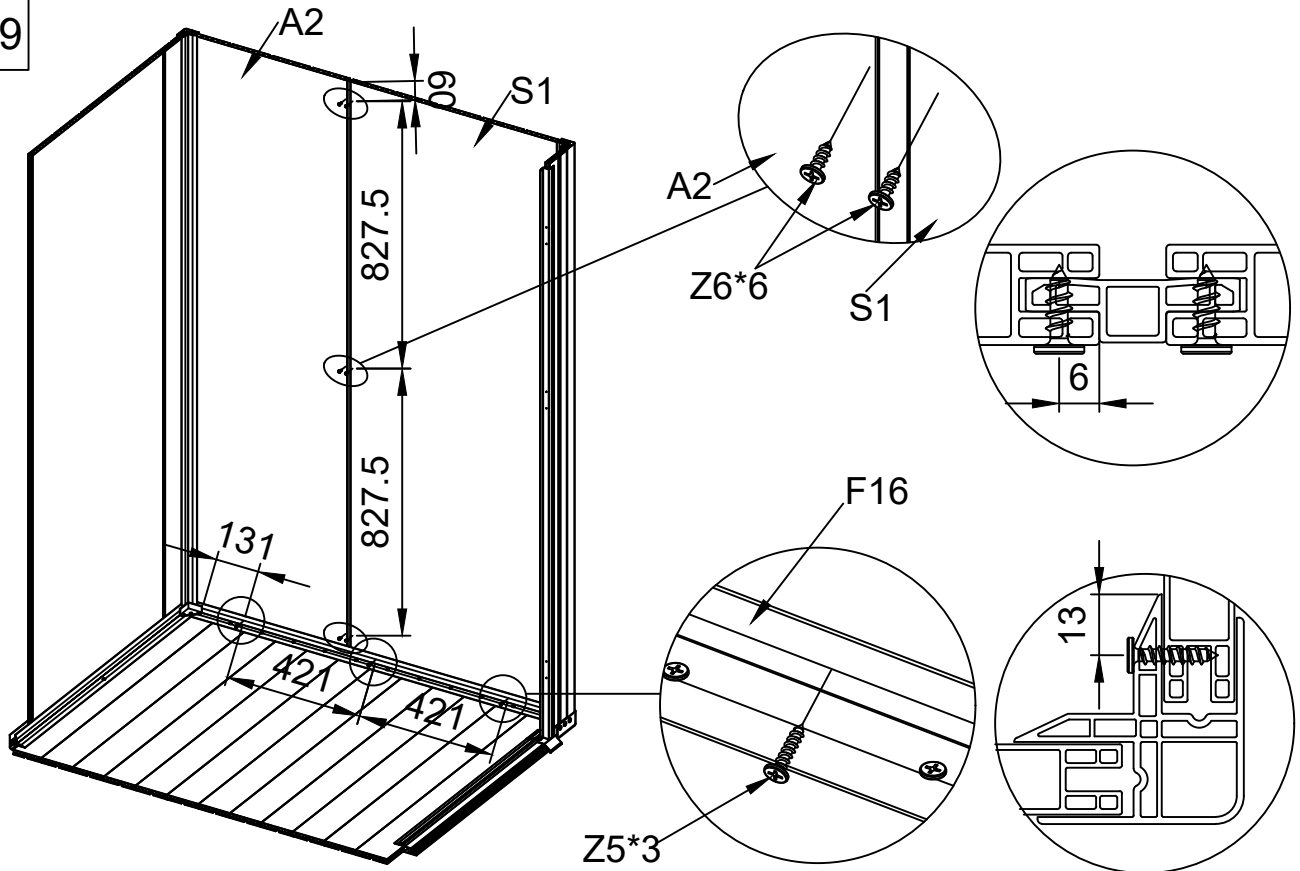

02-20

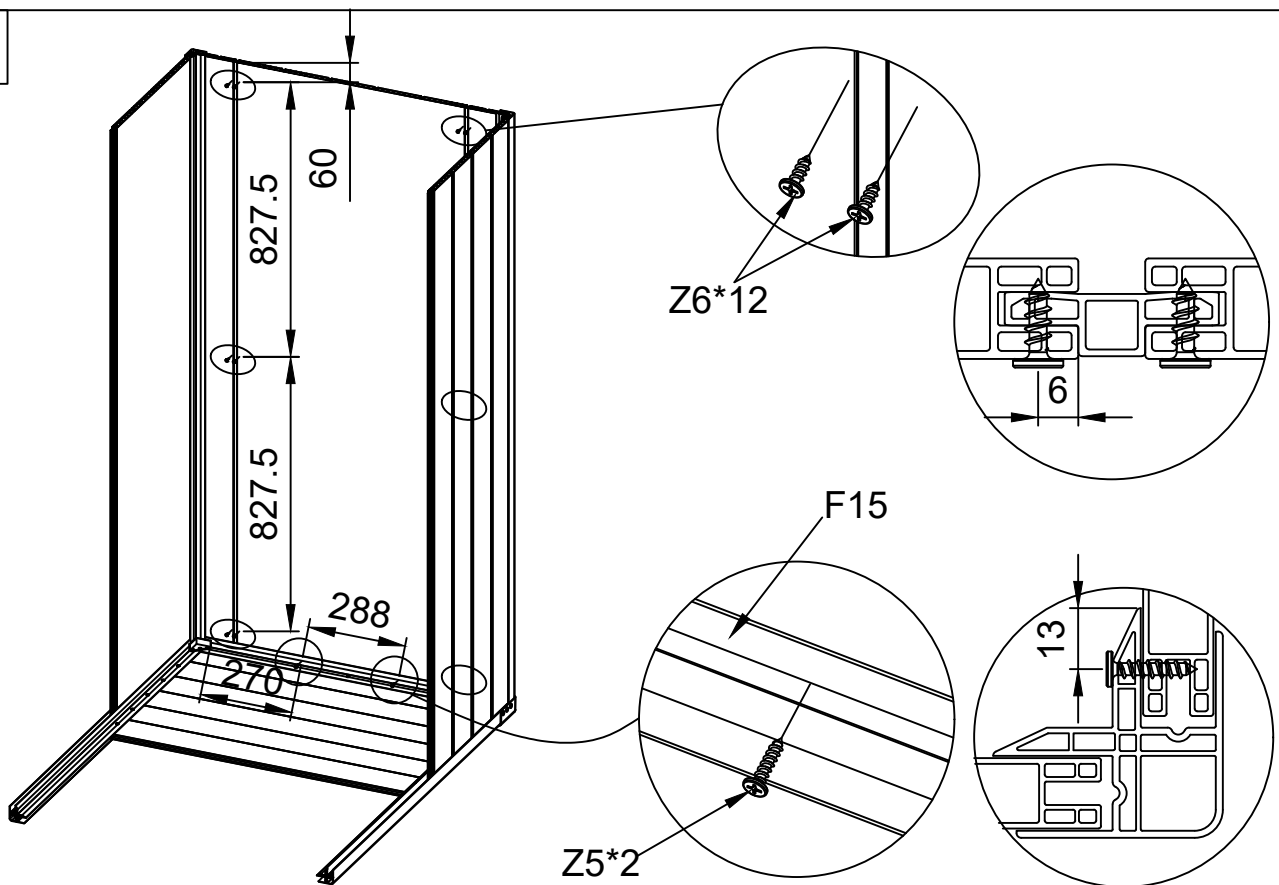



# ASSEMBLY INSTRUCTIONS

A006

02-23

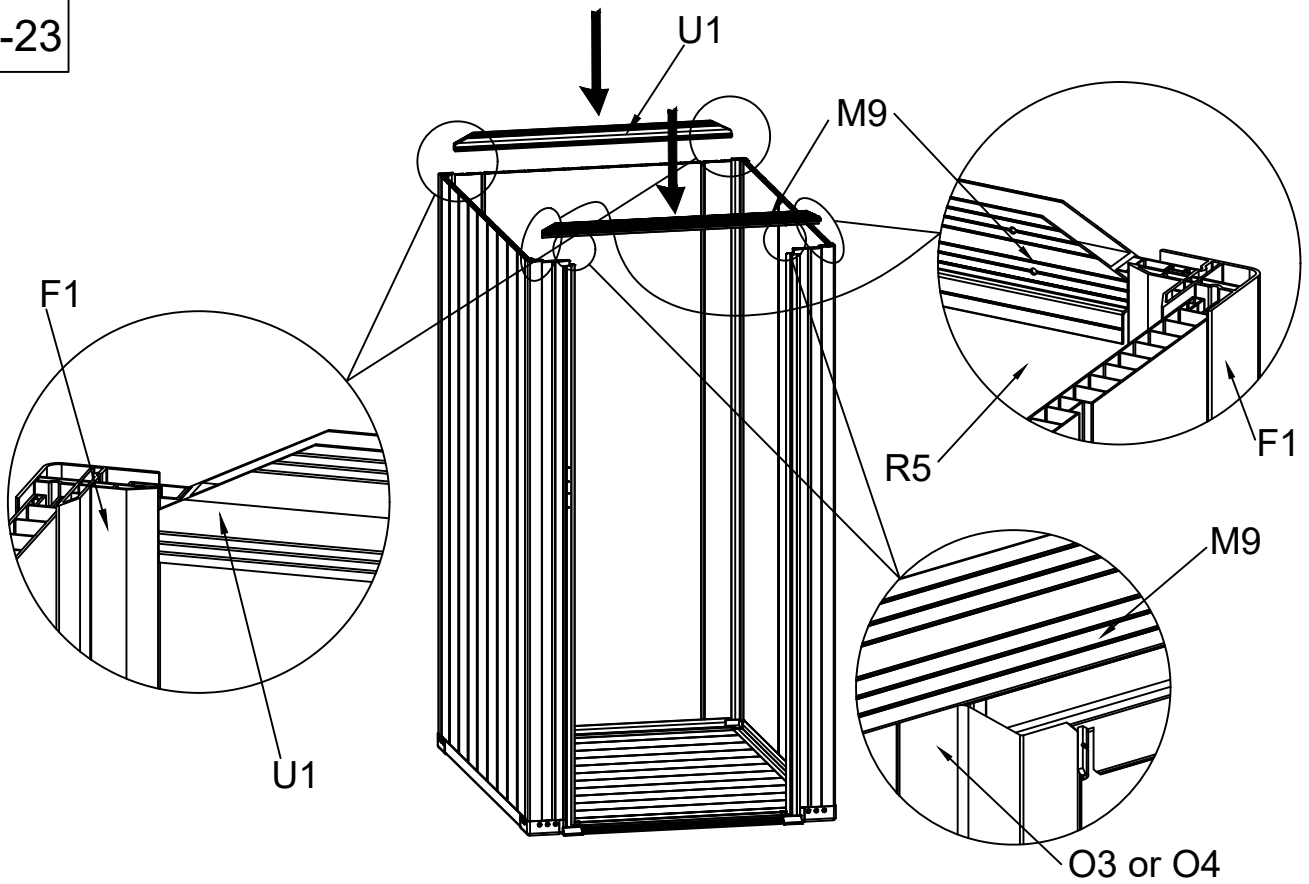

02-24

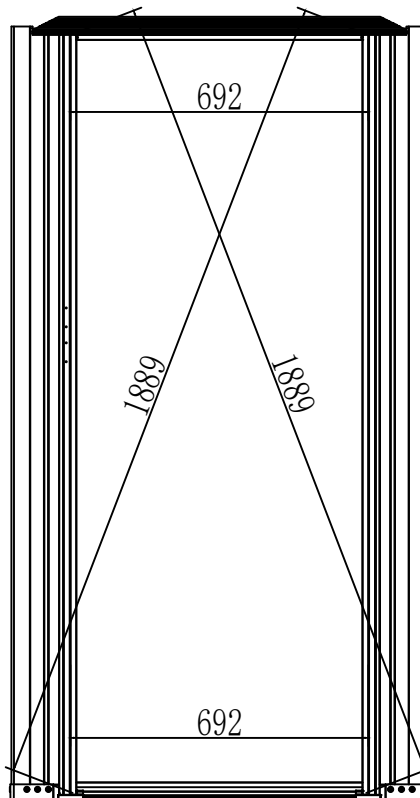

Please make the adjustments according to the dimensions shown in the picture!

# ASSEMBLY INSTRUCTIONS

A006

02-25

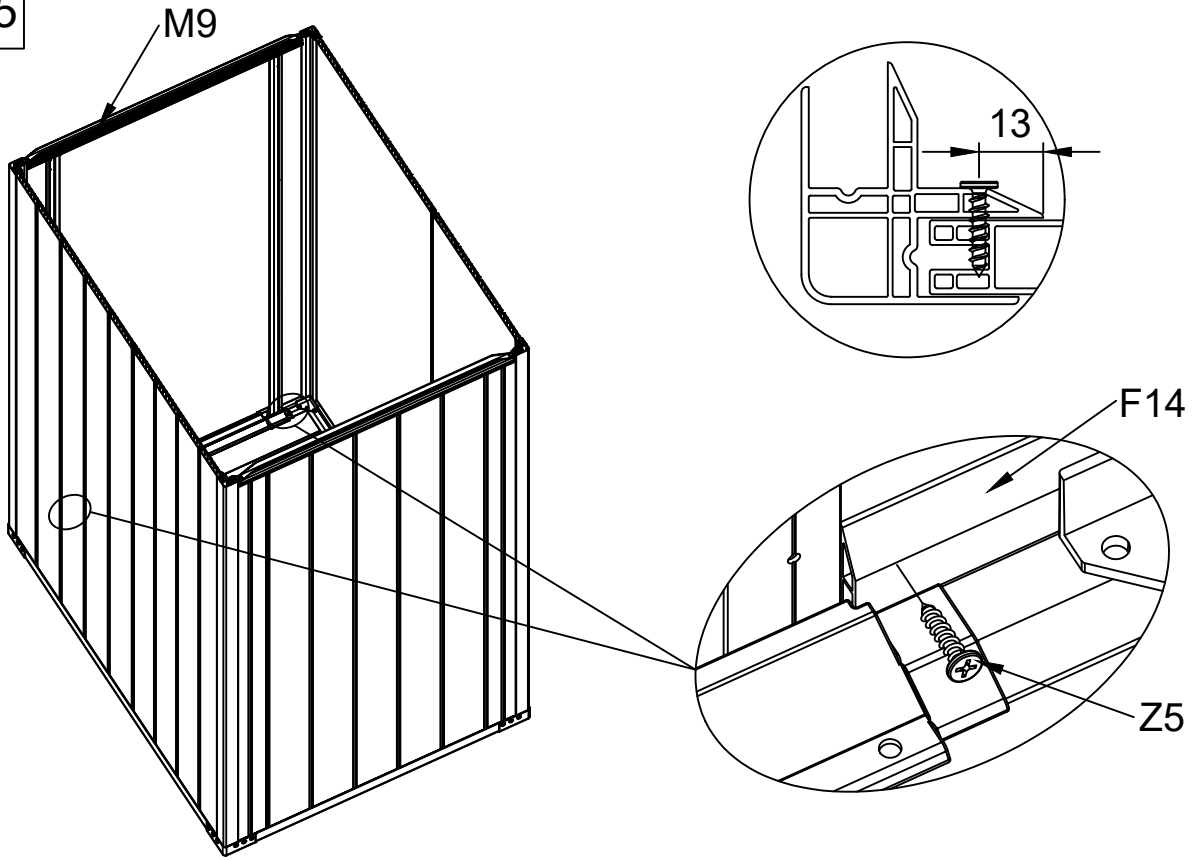

02-26

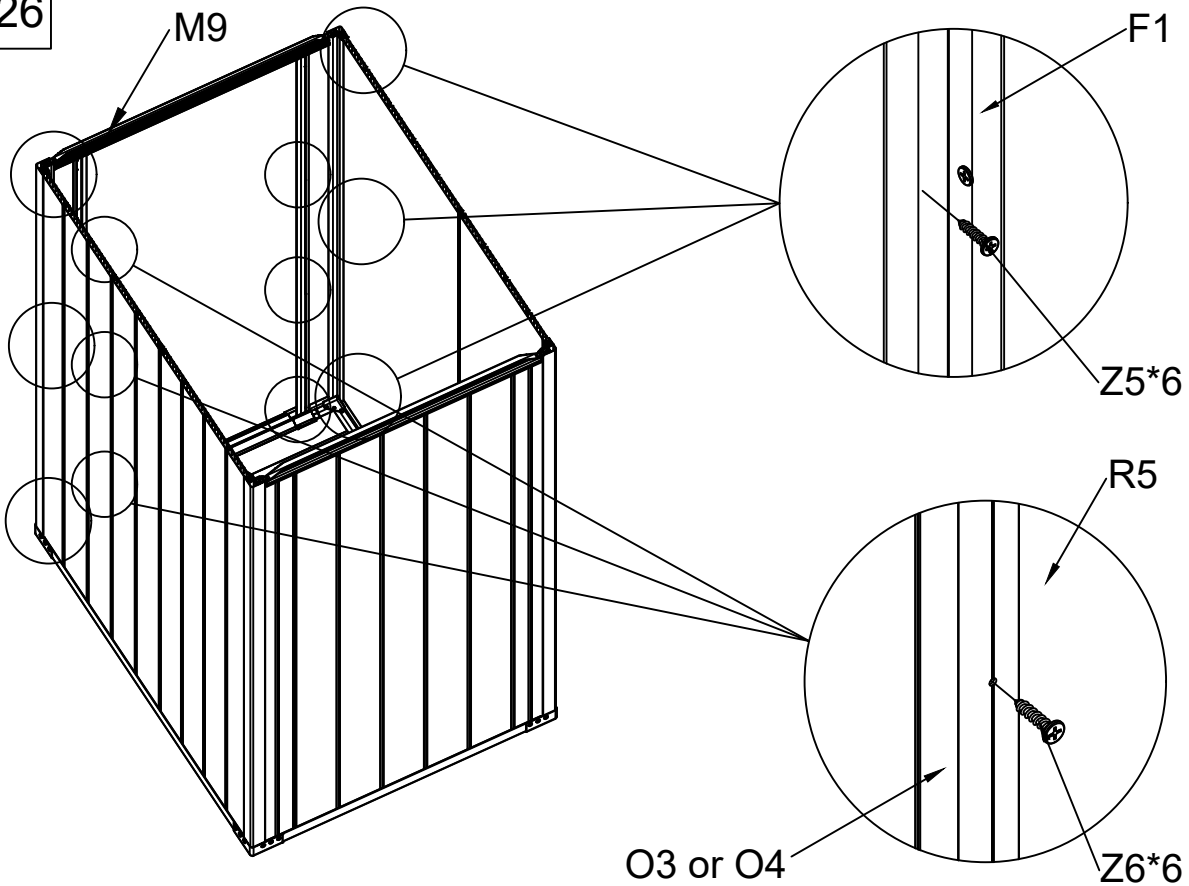

# ASSEMBLY INSTRUCTIONS

A006

02-27

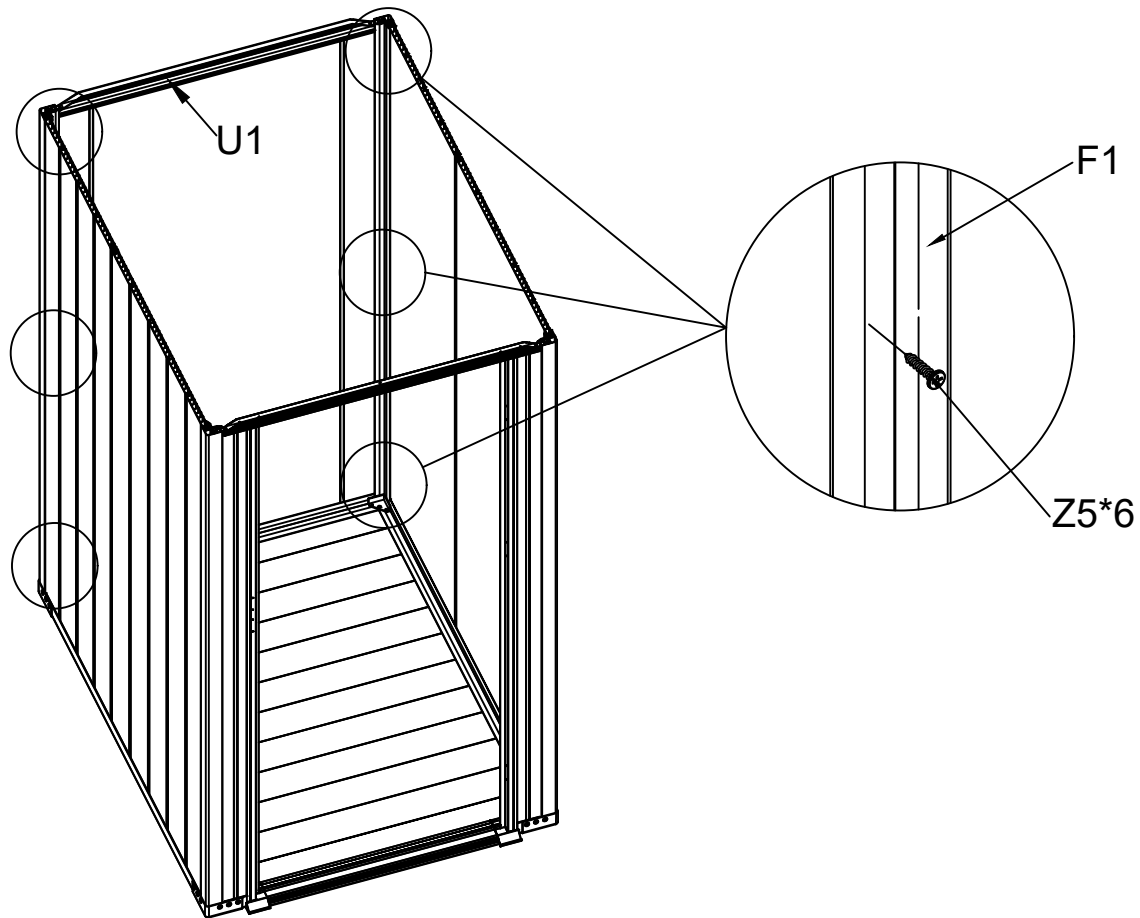

02-28

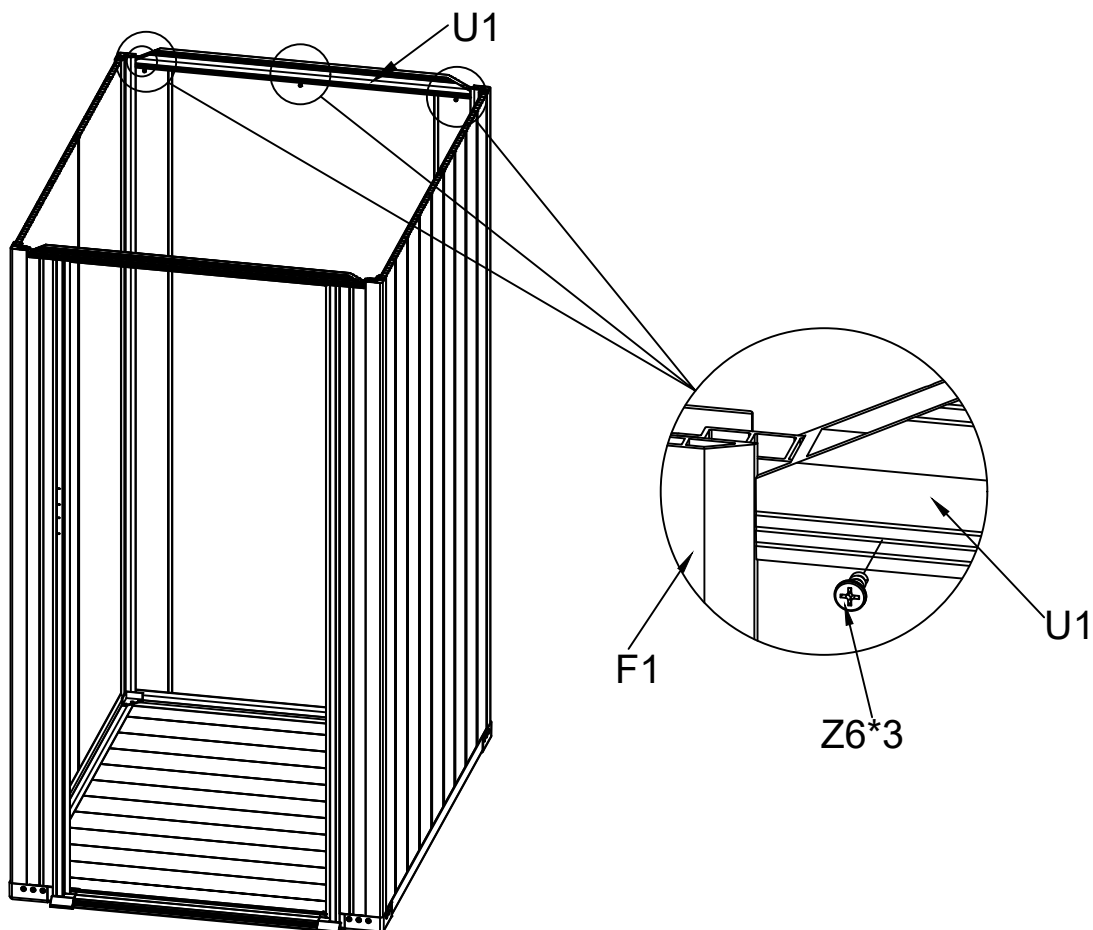

# ASSEMBLY INSTRUCTIONS





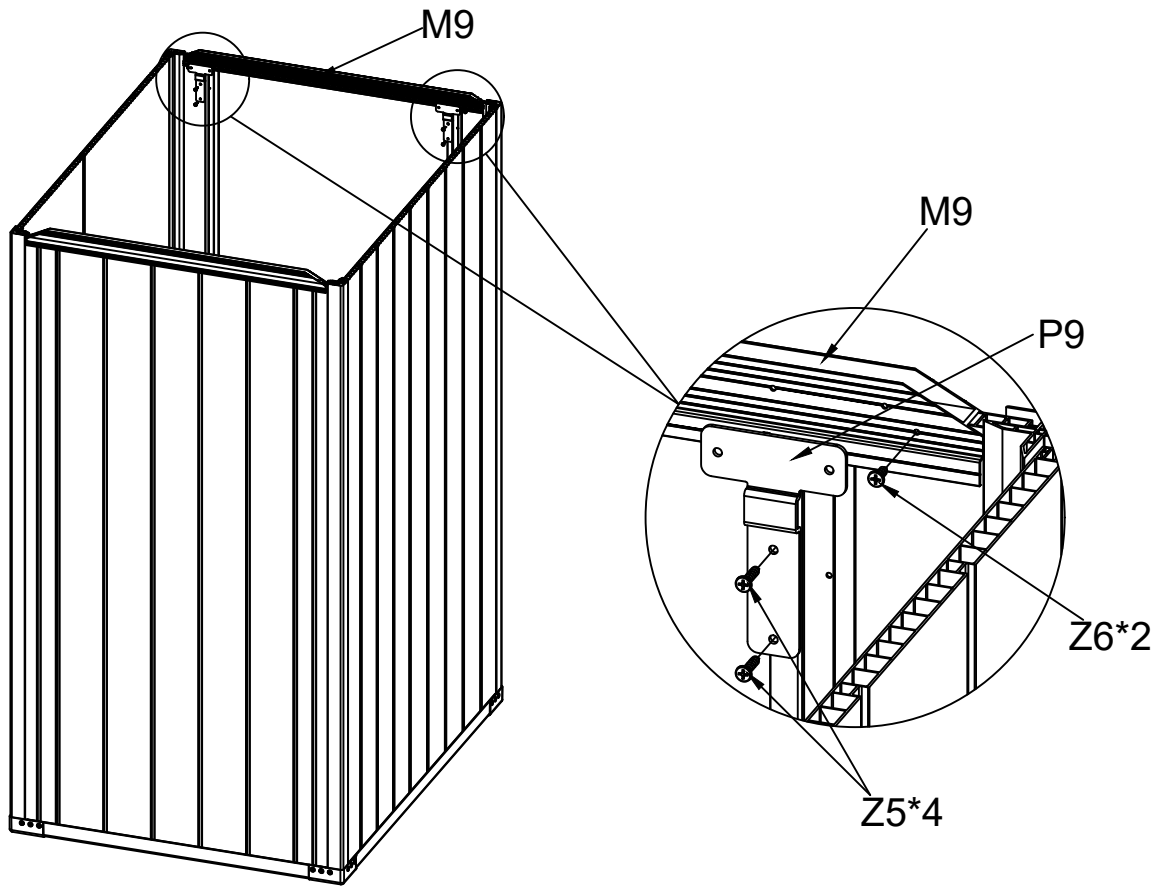







A006

02-29

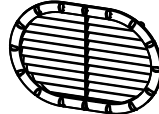

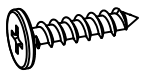
# Step 03 Packing List

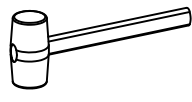
A006

 235*15*918 <b>B10 1pc</b>	 235*15*918 <b>B11 1pc</b>	  L=1144 <b>G11 2pcs</b>	  <b>I5 4pcs</b>	 <b>Q15 1pc</b>	 <b>Q16 1pc</b>
 ST4.0*18 <b>Z5 12pcs</b>	 ST4.0*12 <b>Z6 28pcs</b>	 <b>Za 1pc</b>	 <b>Zb 1pc</b>		

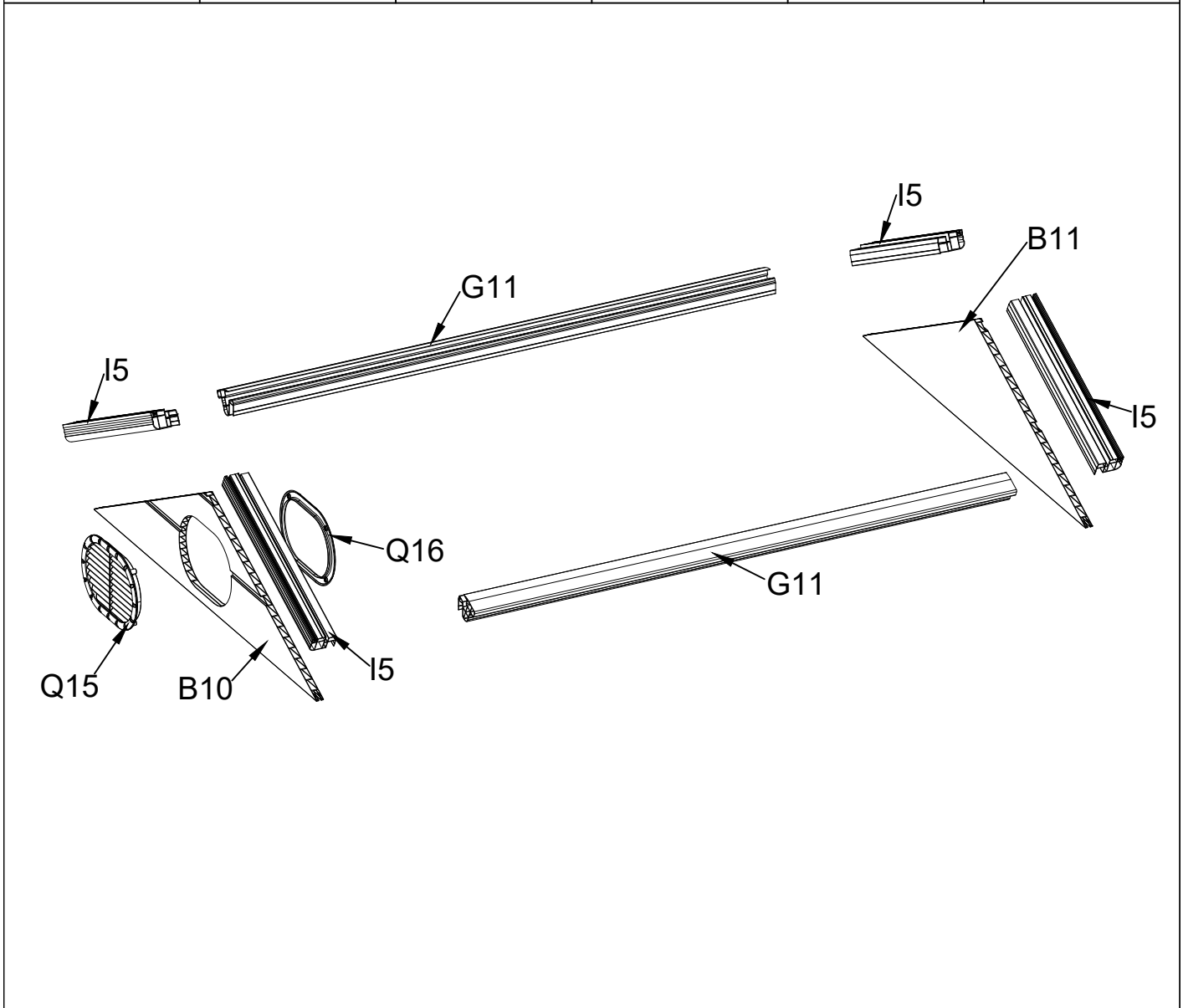

# ASSEMBLY INSTRUCTIONS

A006

03-01

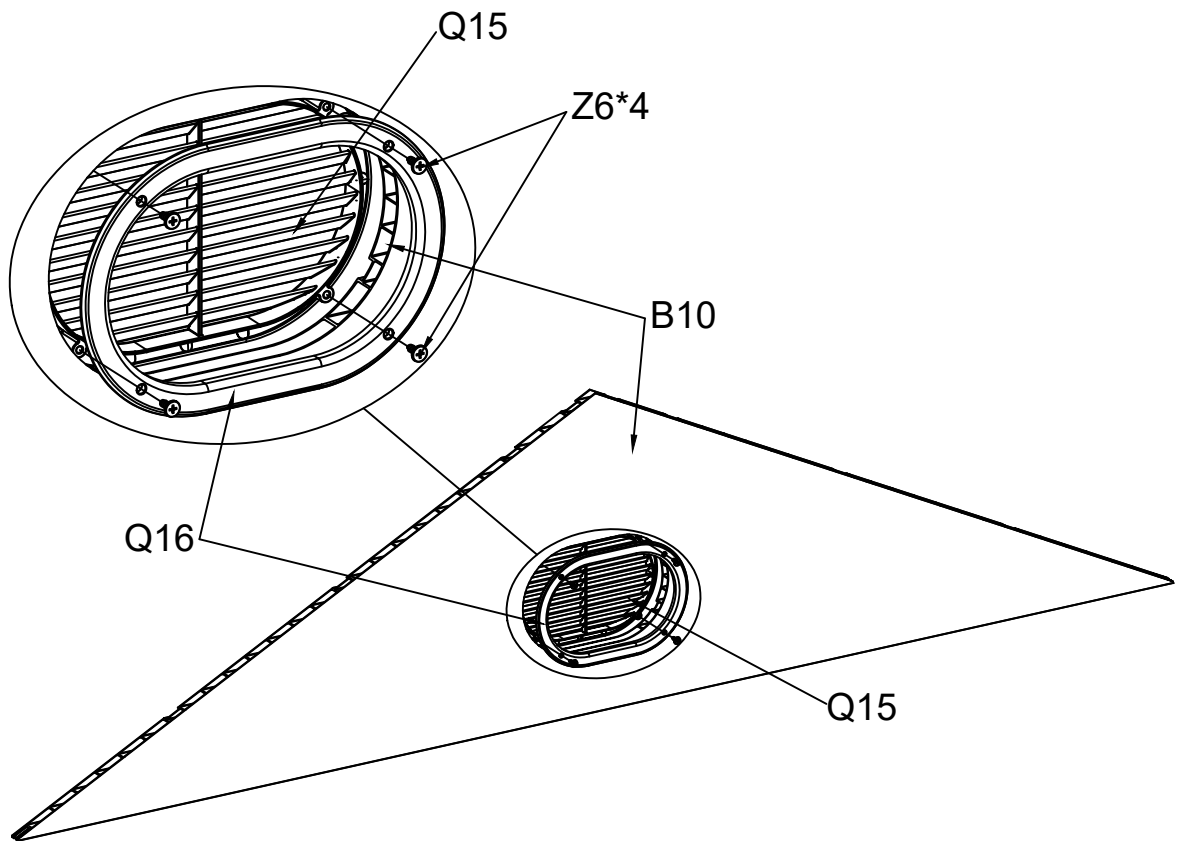

03-02

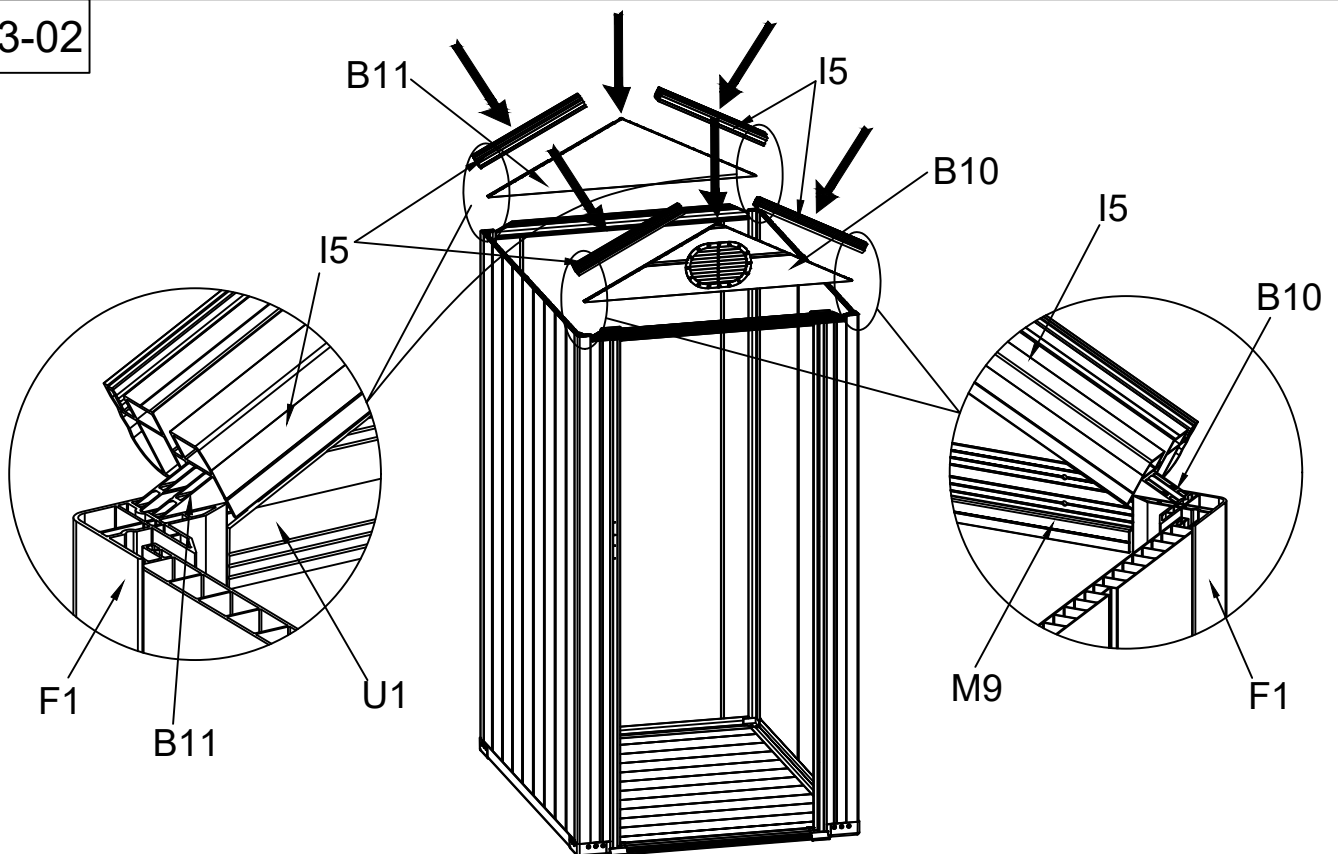

# ASSEMBLY INSTRUCTIONS

A006

03-03

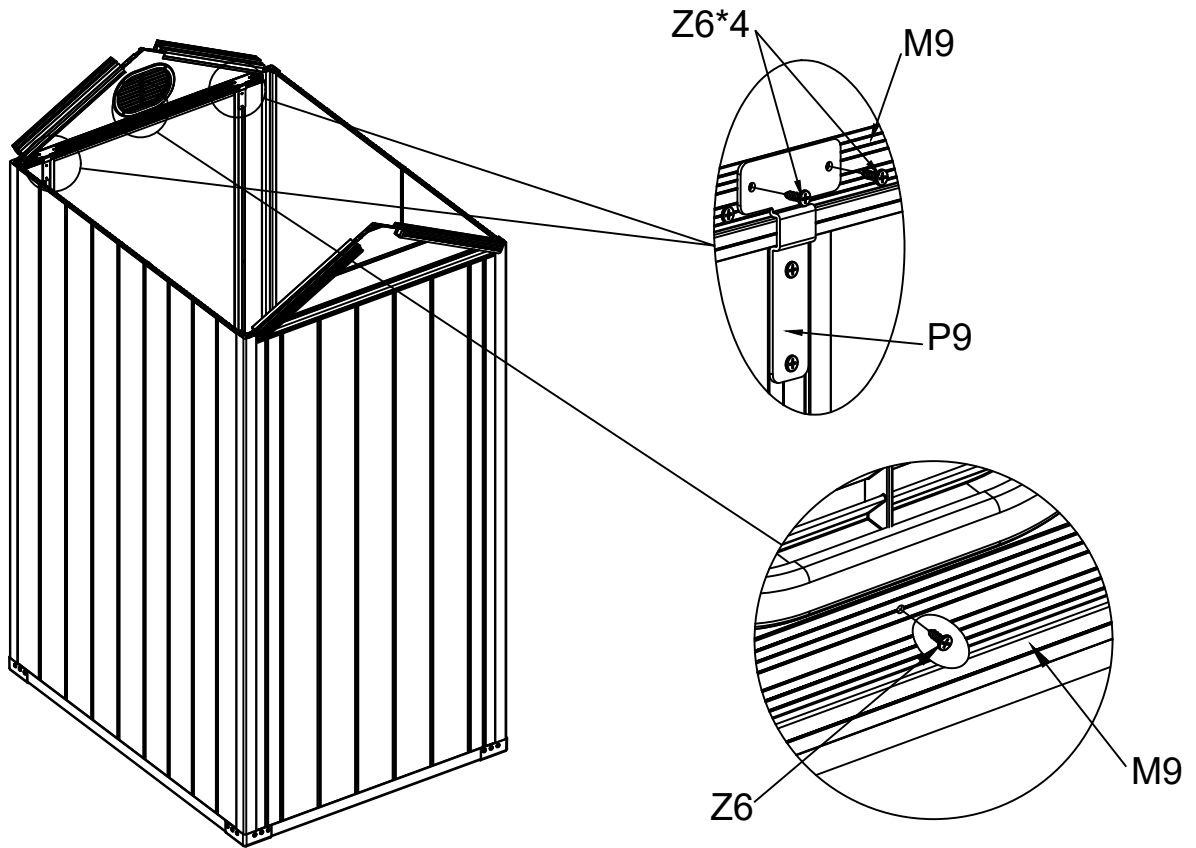

03-04

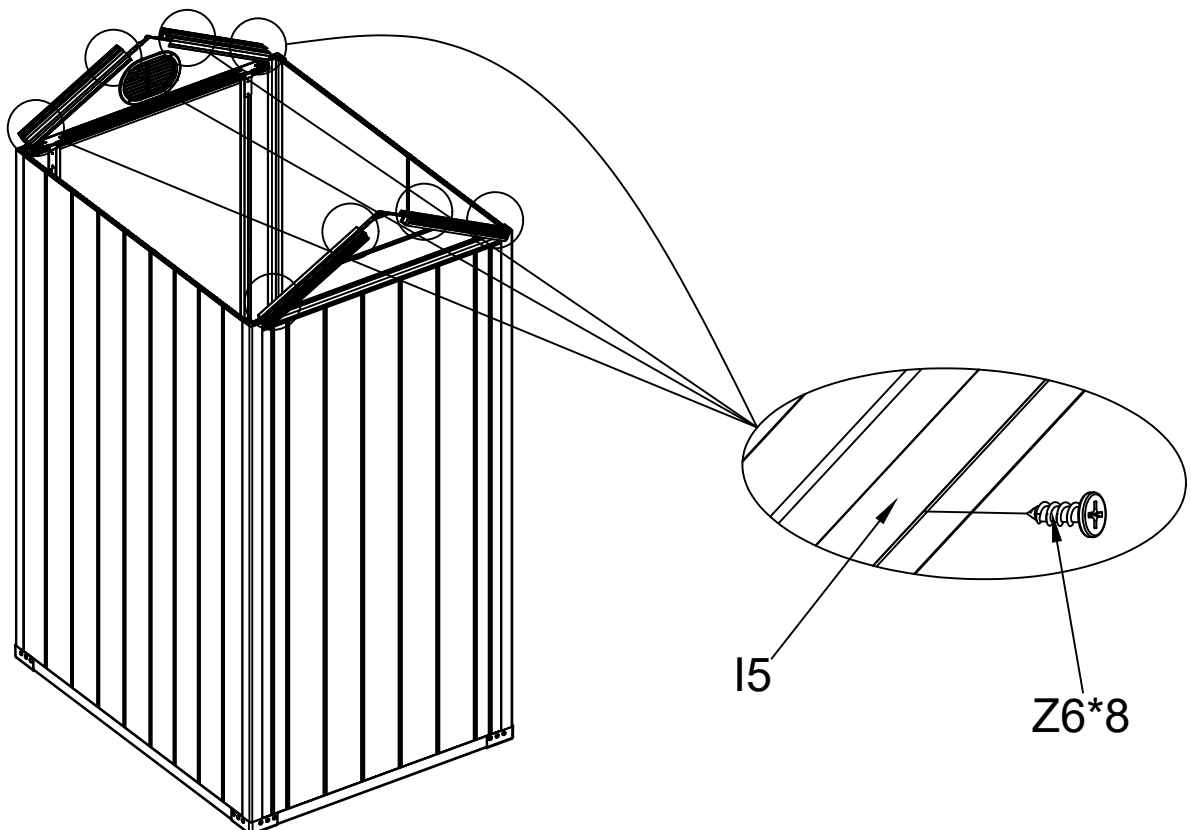

# ASSEMBLY INSTRUCTIONS

A006

03-05

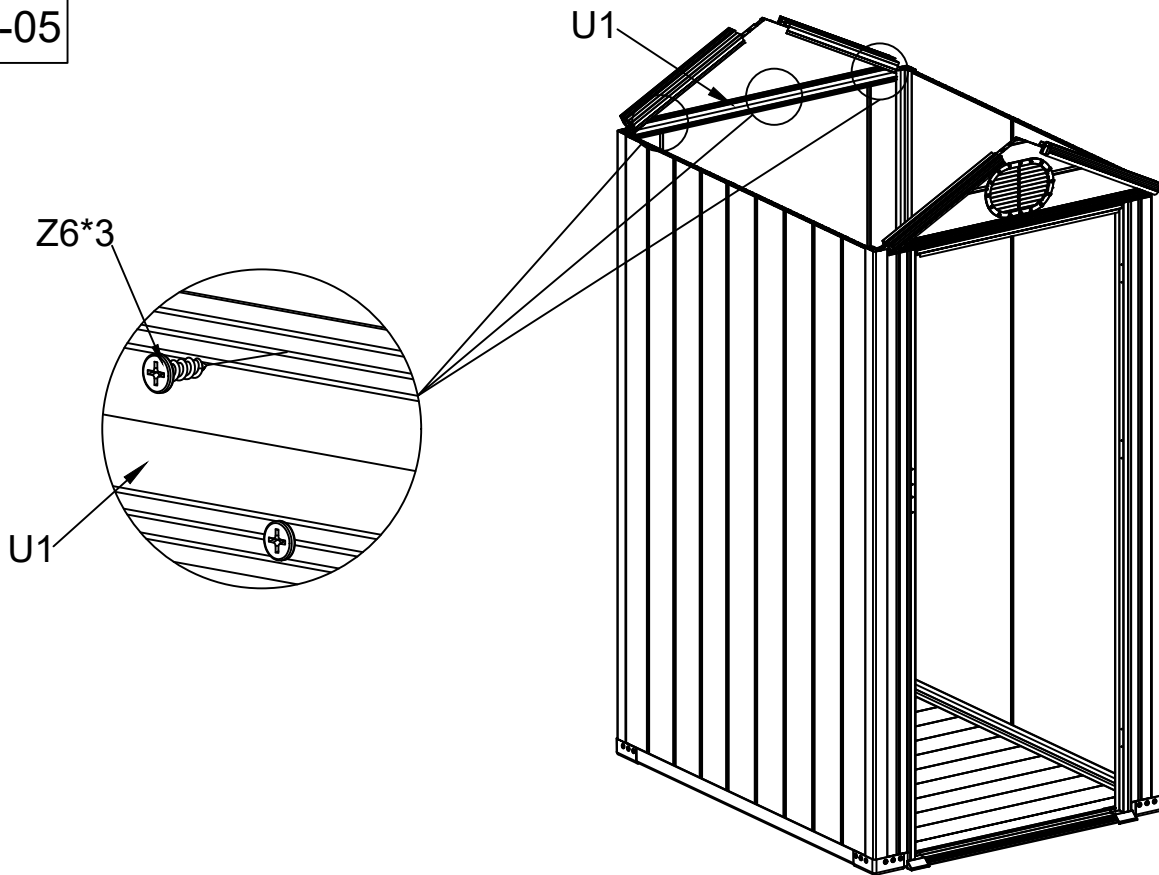

03-06

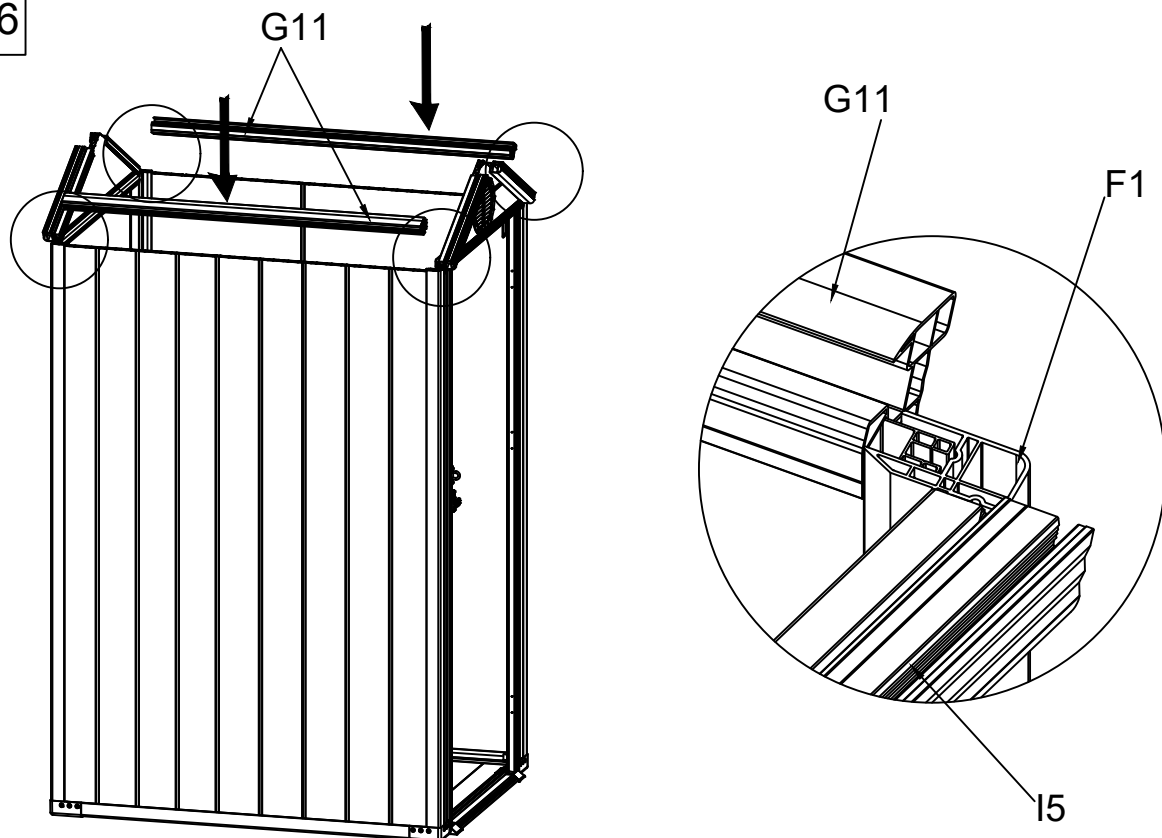

# ASSEMBLY INSTRUCTIONS

A006

03-07

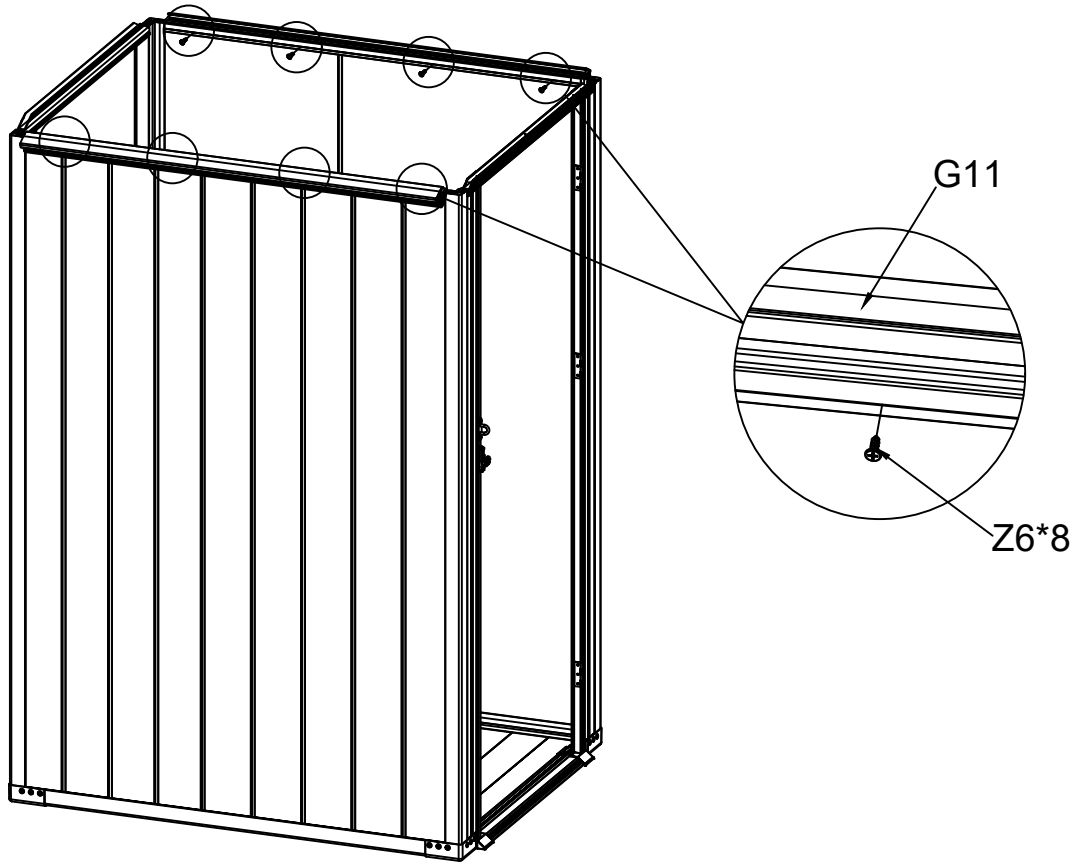

03-08

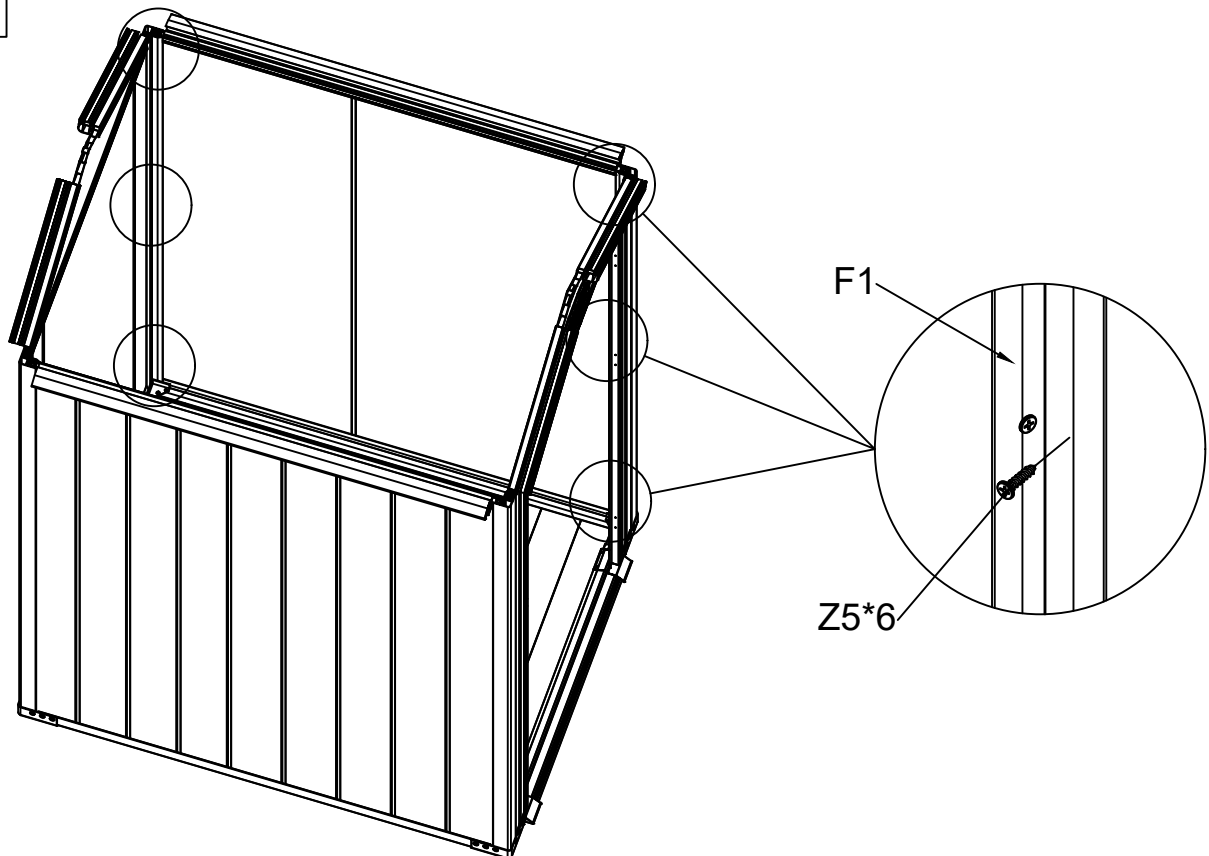

# ASSEMBLY INSTRUCTIONS





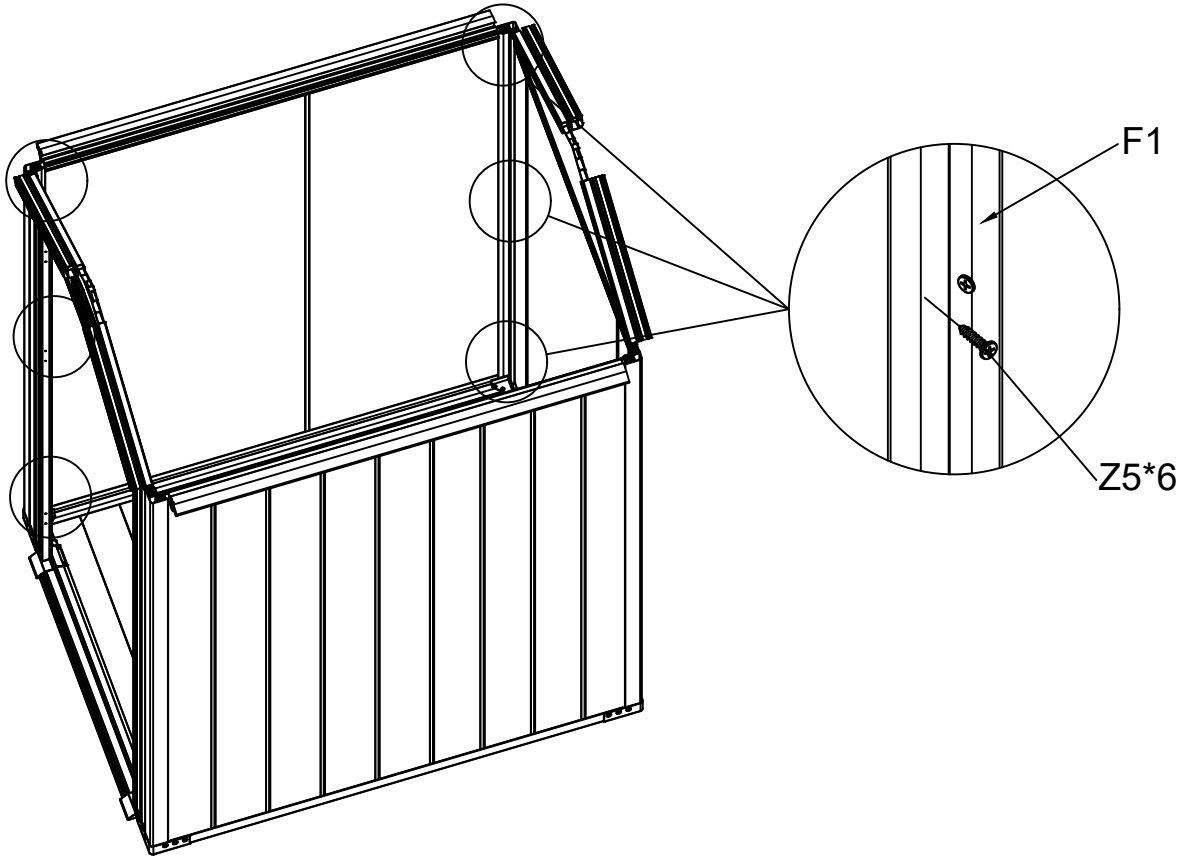

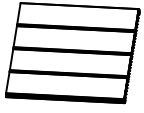

A006

03-09

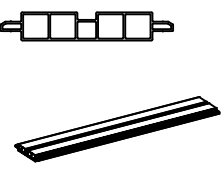
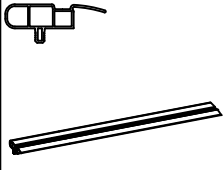
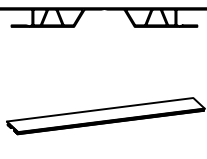

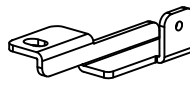
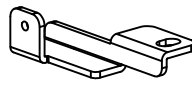
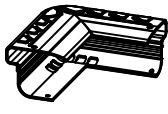
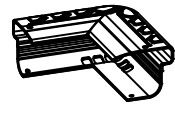
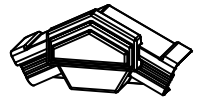
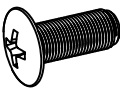
# Step 04 Packing List

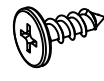
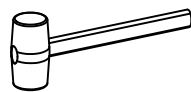
A006

					
500*15*492	680*15*492				51*18*0.8*1197
A10 2pcs	S8 2pcs	D5 2pcs	H5 4pcs	J7 1pc	K14 2pcs
					
P5 2pcs	P7 2pcs	P8 2pcs	Q6 2pcs	Q7 2pcs	Q14 2pcs
					
M6*15	Ø13*Ø6.5*1.0	ST4.0*18	ST4.0*12		
Z1 4pcs	Z4 4pcs	Z5 12pcs	Z6 44pcs	Za 1pc	Zb 1pc

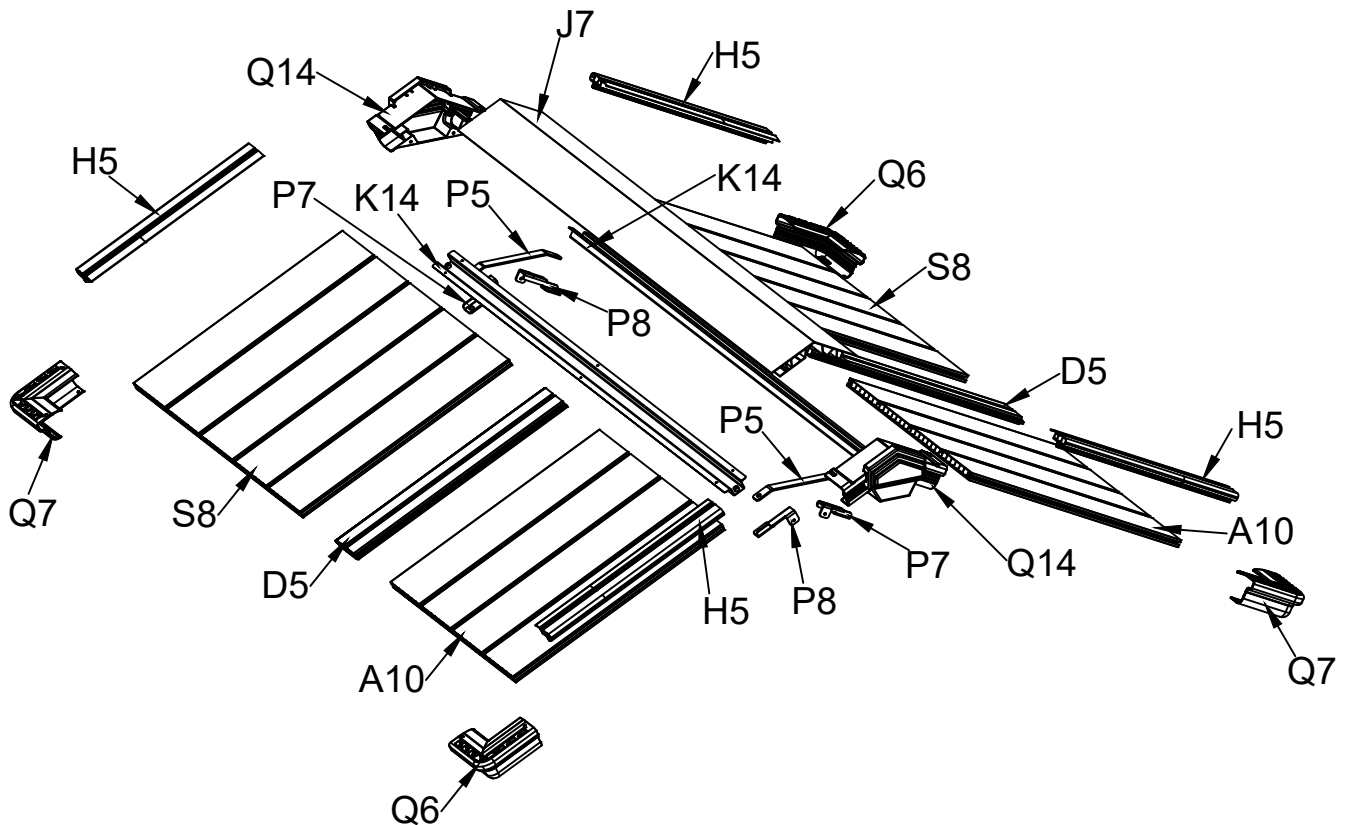

# ASSEMBLY INSTRUCTIONS

A006

04-01

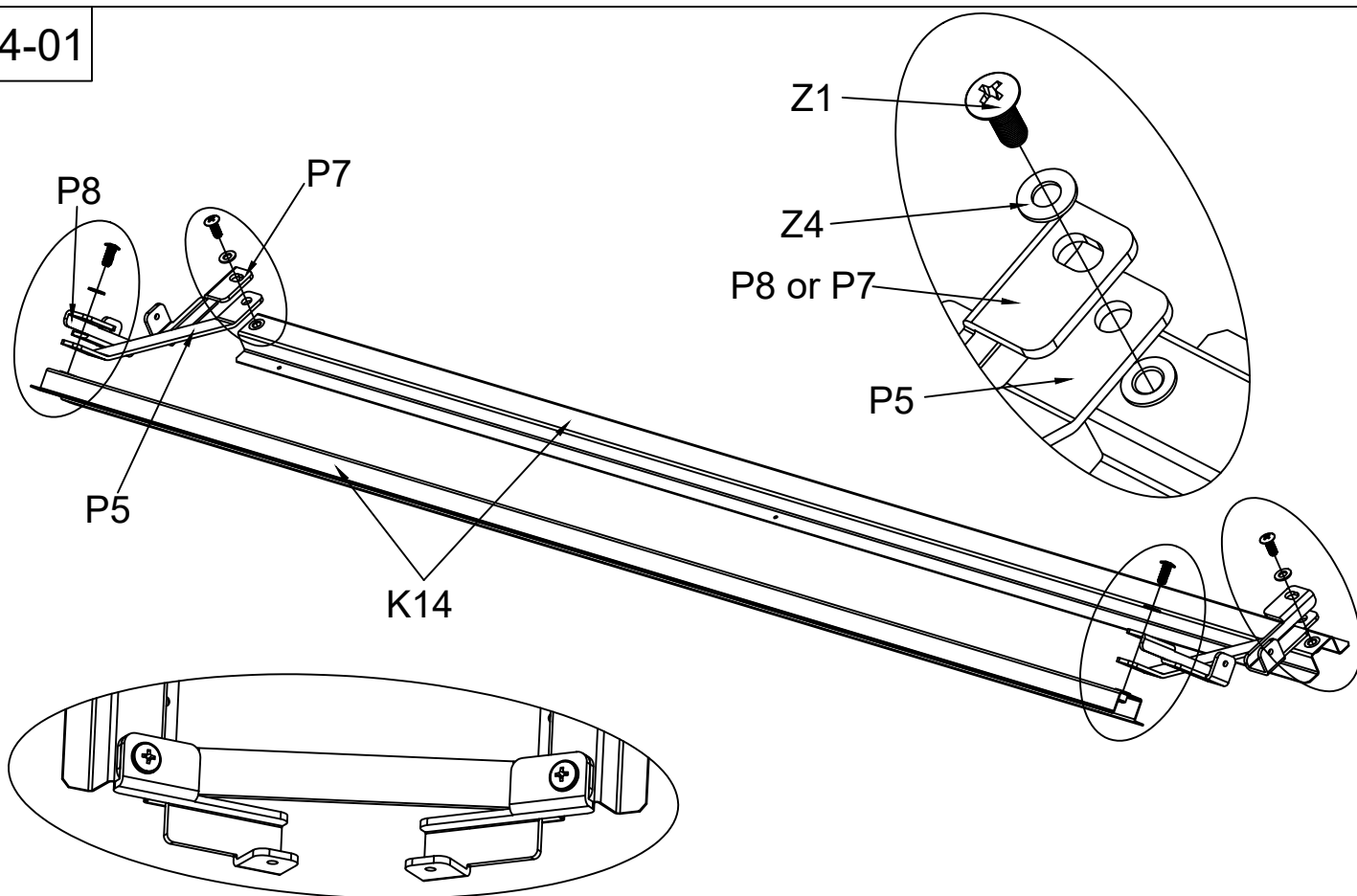

04-02

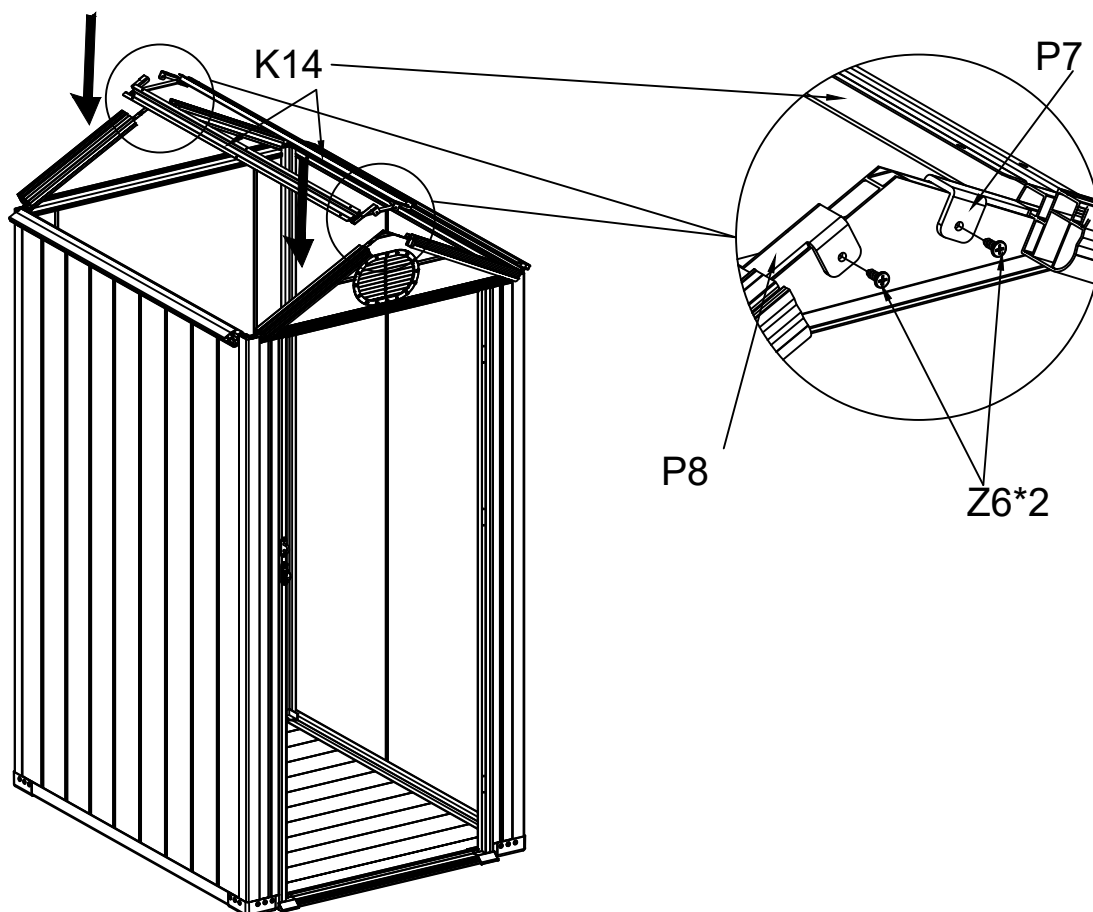

# ASSEMBLY INSTRUCTIONS

A006

04-03

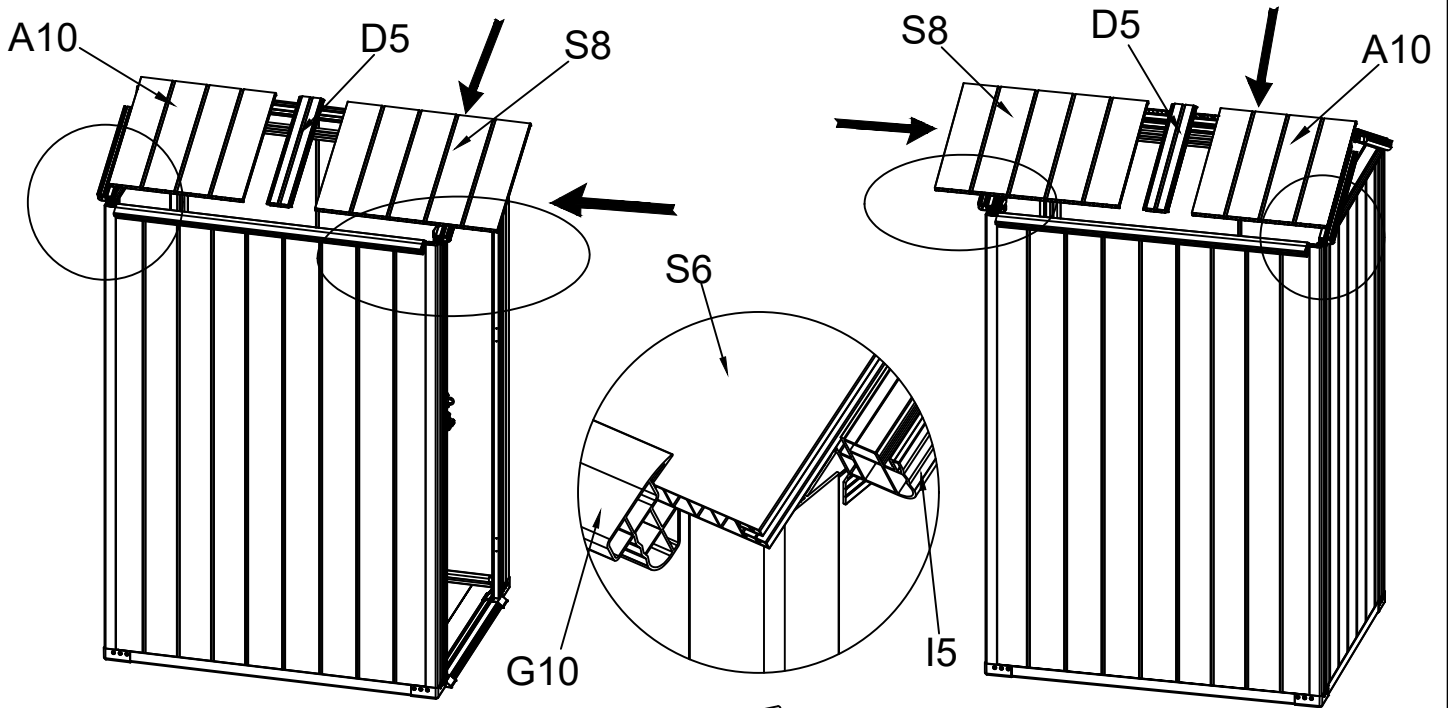

Please use the part "Za" to fasten each part "S8" and "D5" and "A10" and "G10" !

If any difficult during the assemble, pls use Part "Zb" for assistance!

04-04

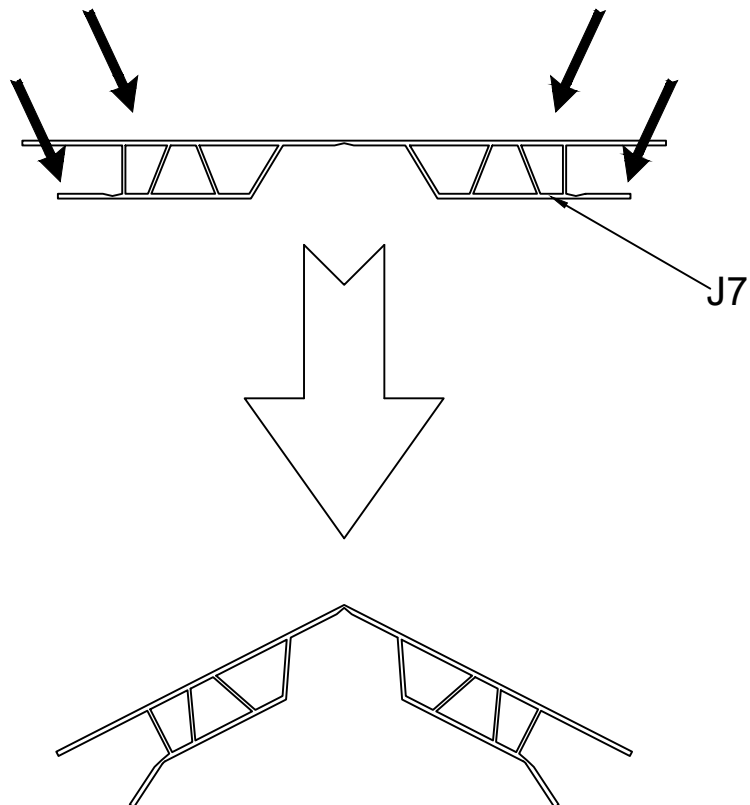

# ASSEMBLY INSTRUCTIONS

A006

04-05

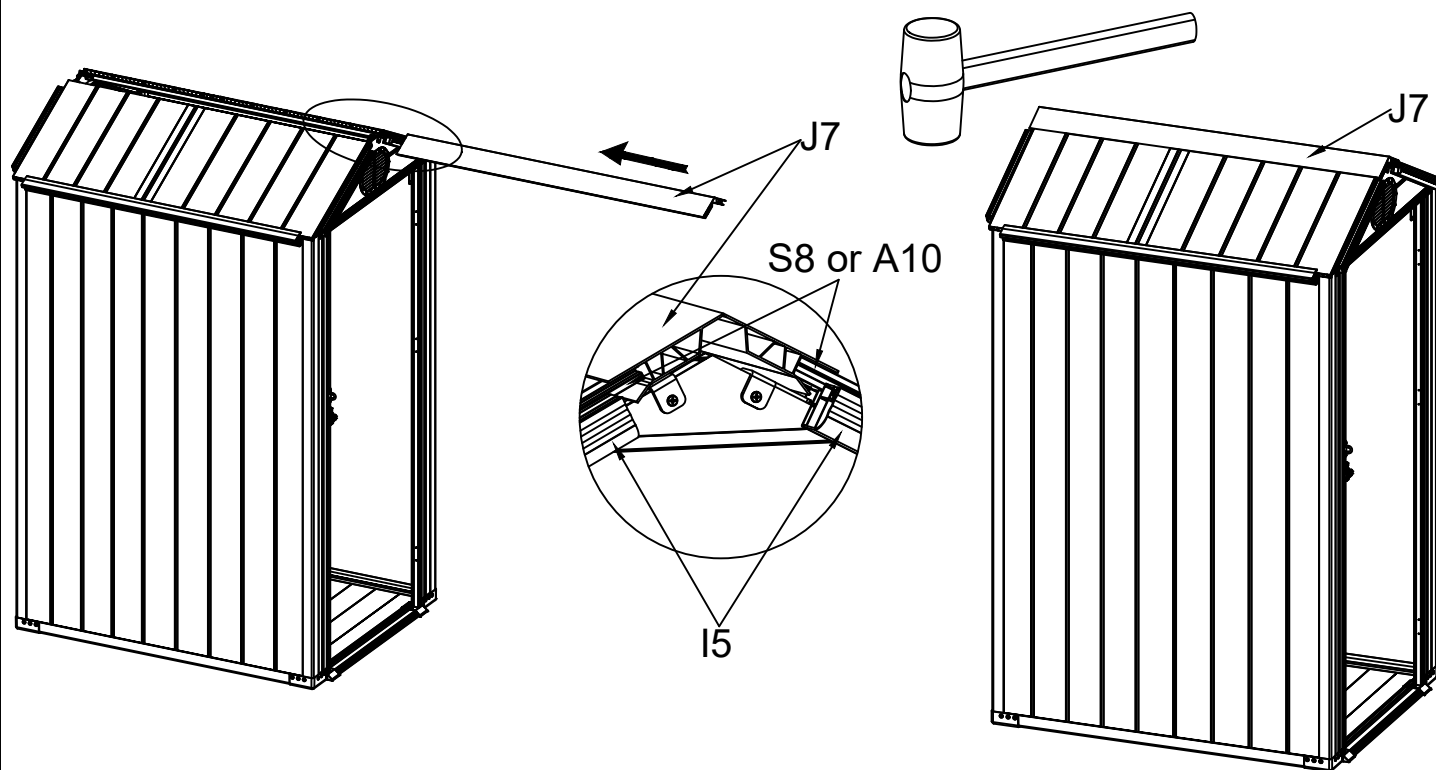

04-06

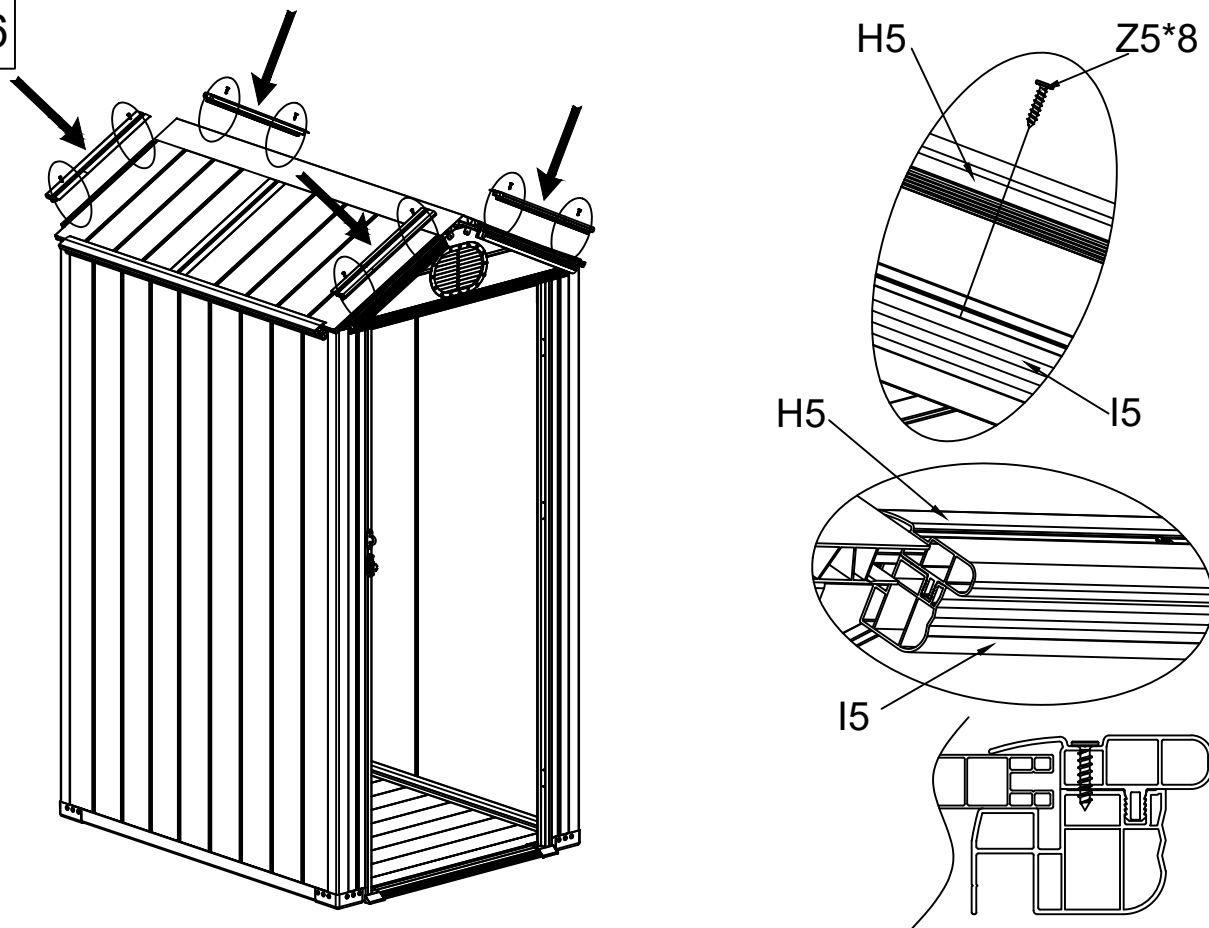

# ASSEMBLY INSTRUCTIONS

A006

04-07

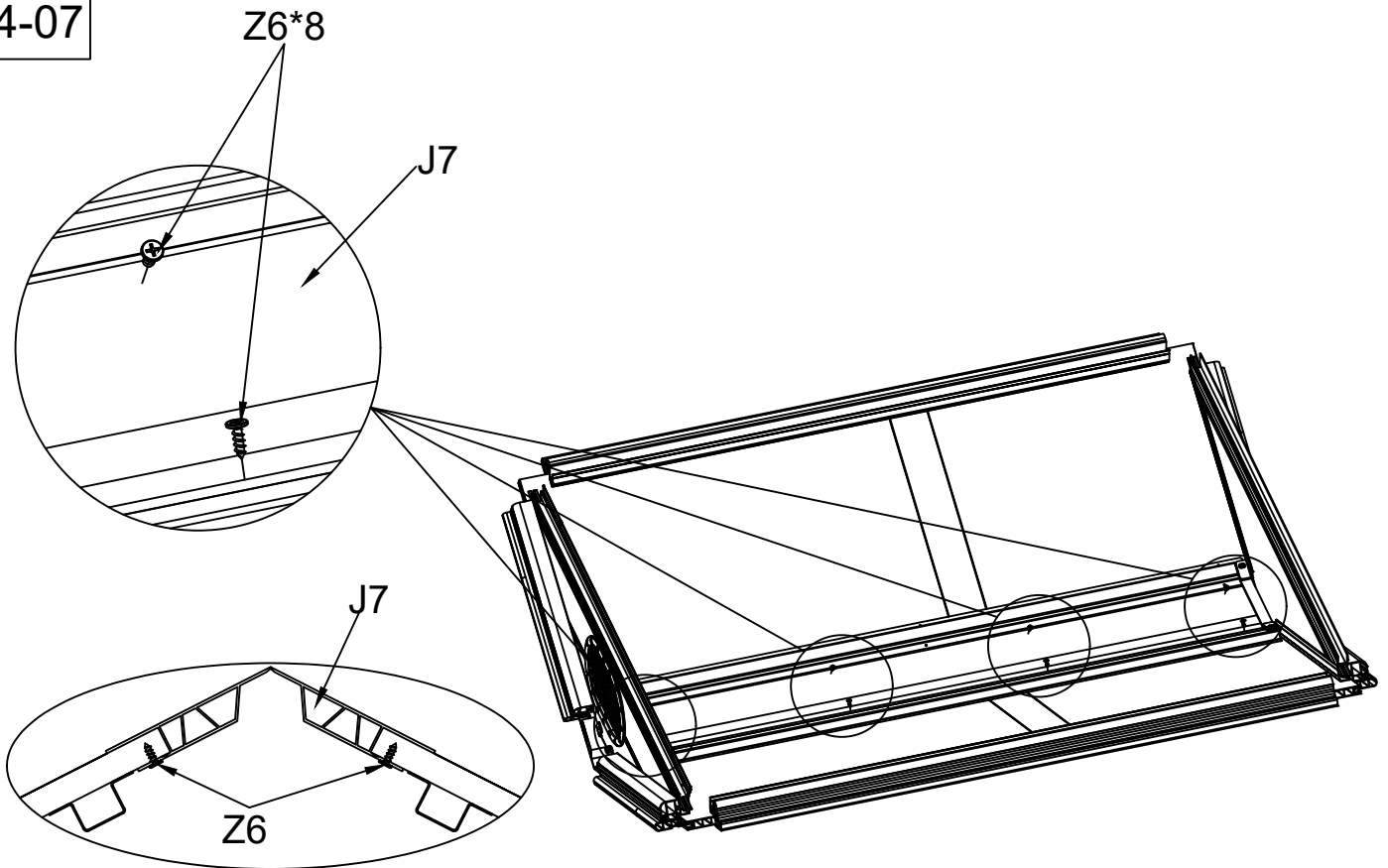

04-08

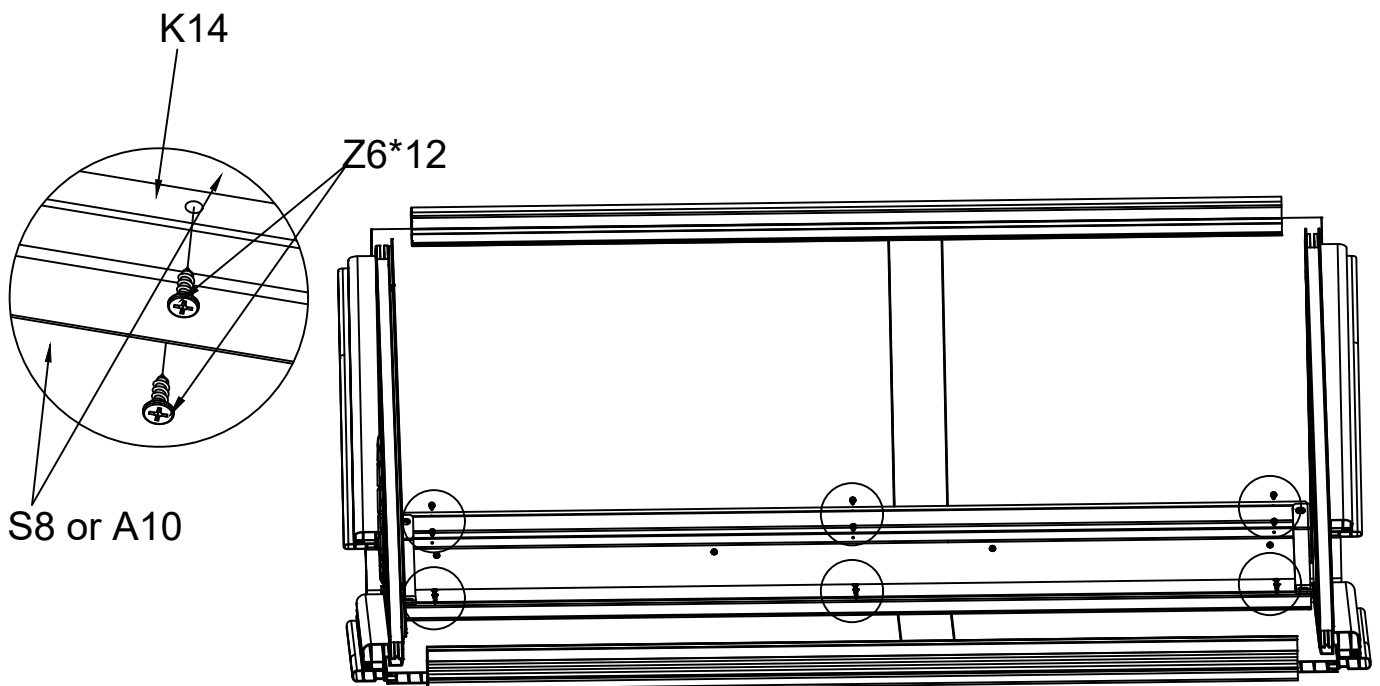

# ASSEMBLY INSTRUCTIONS

A006

04-09

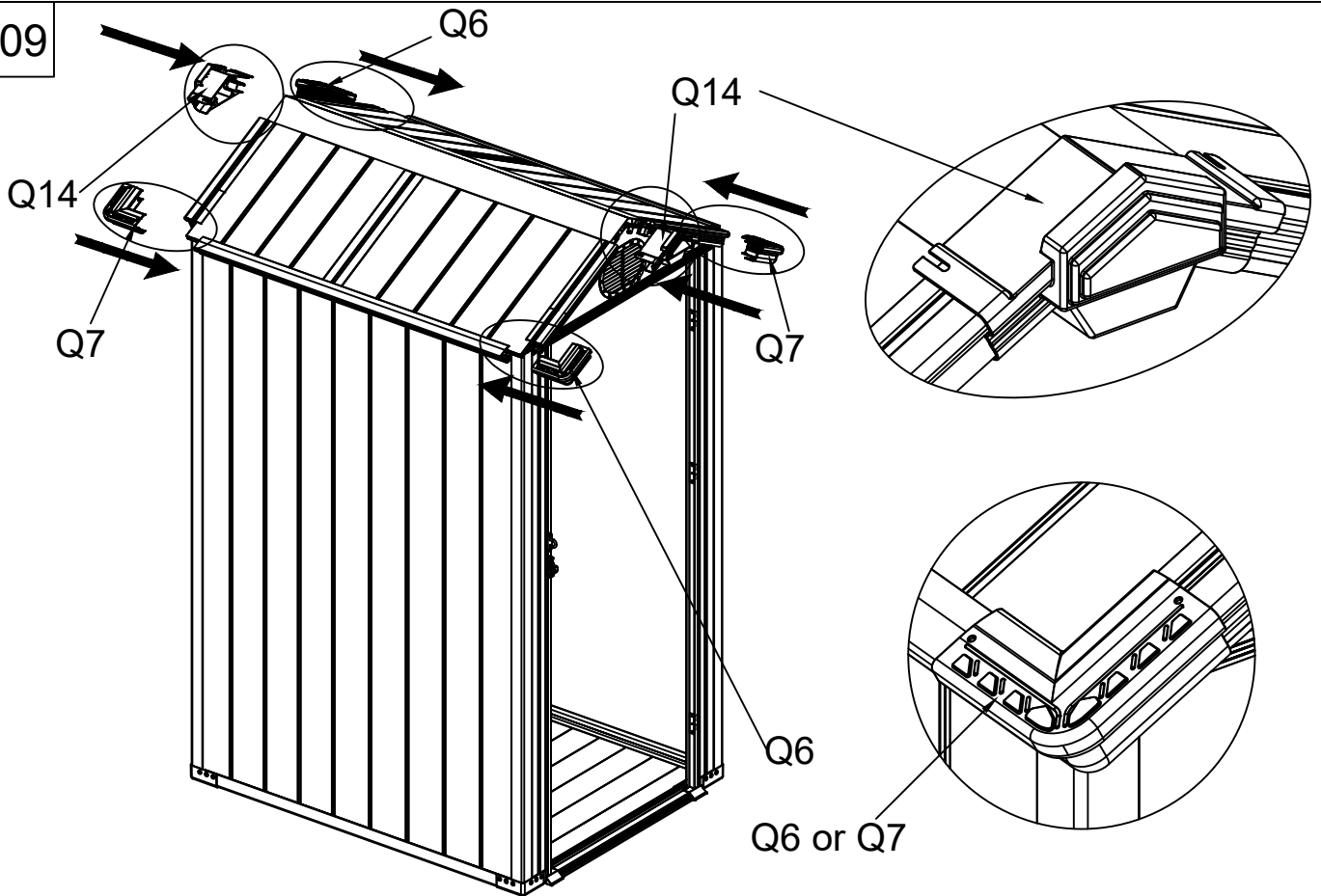

04-10

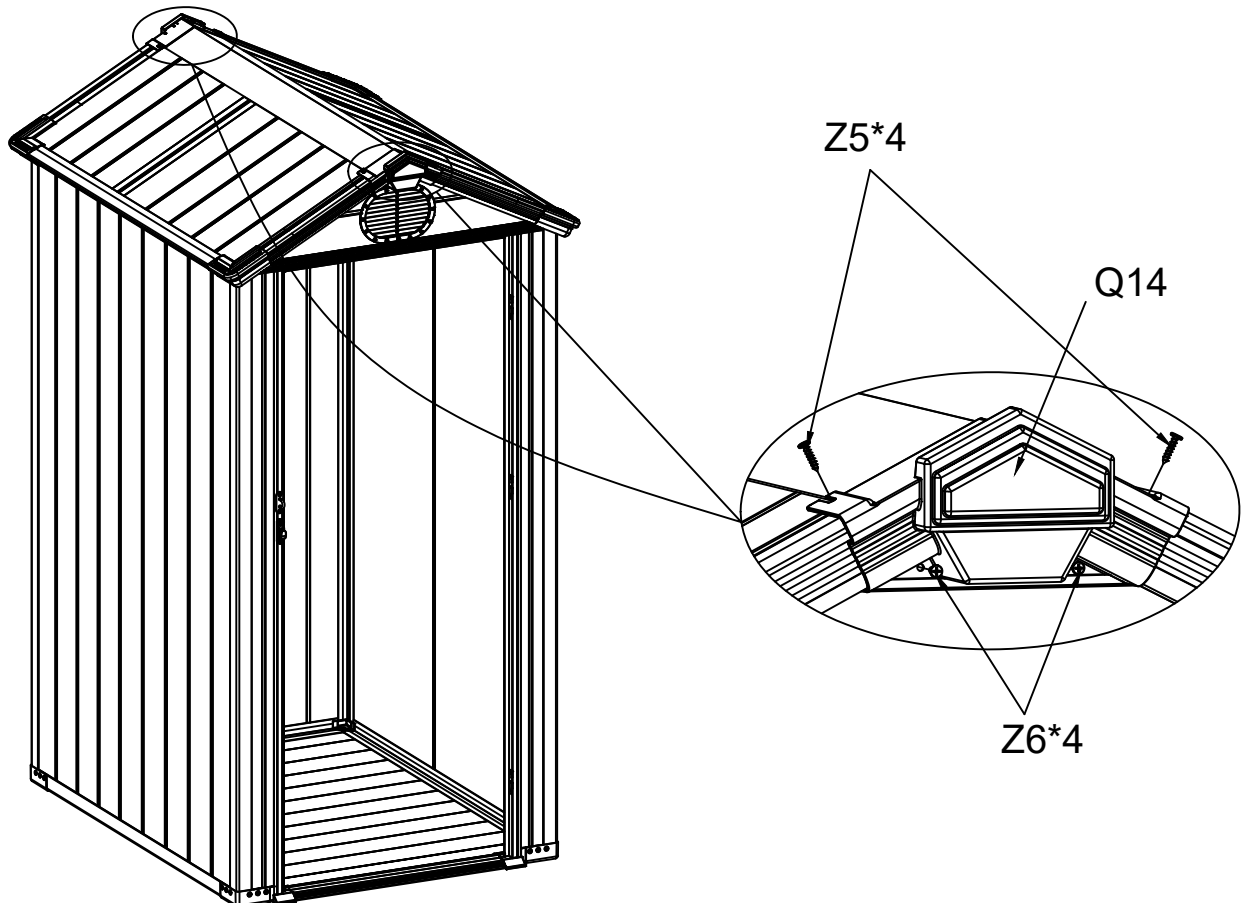

# ASSEMBLY INSTRUCTIONS





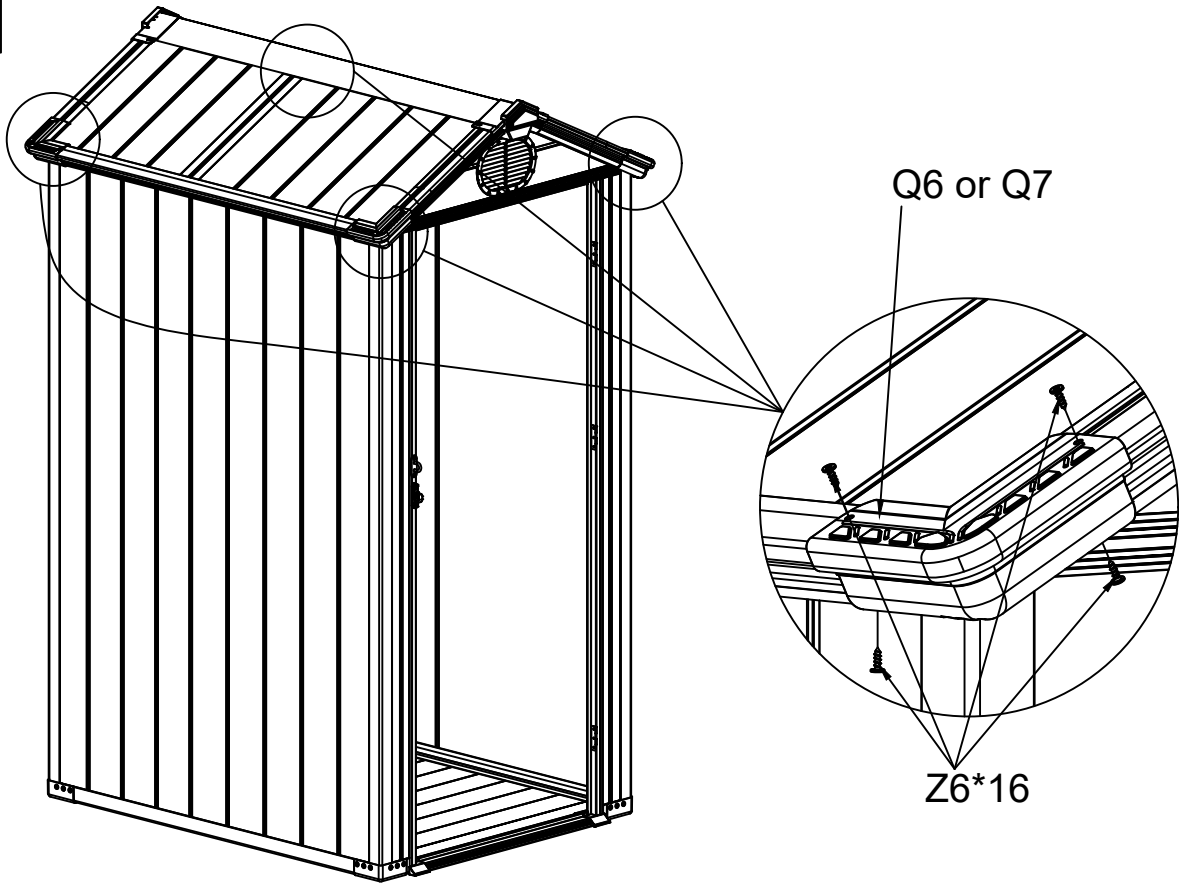



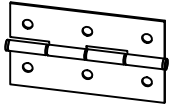
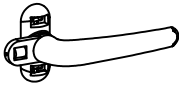
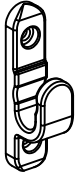
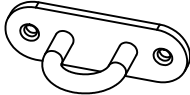

A006

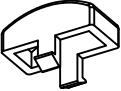
04-11



# Step 05 Packing List

A006

 682*17*1755	 P16 3pcs	 P18 1pc	 P19 1pc	 P20 2pcs	 Q1 2pcs
 Q2 2pcs	 Q3 1pc	 Q4 1pc	 Q5 1pc	 Q8 2pcs	 ST4.0*18 Z5 12pcs
 ST4.0*12 Z6 10pcs	 ST4.0*17 Z11 6pcs				

# ASSEMBLY INSTRUCTIONS

A006

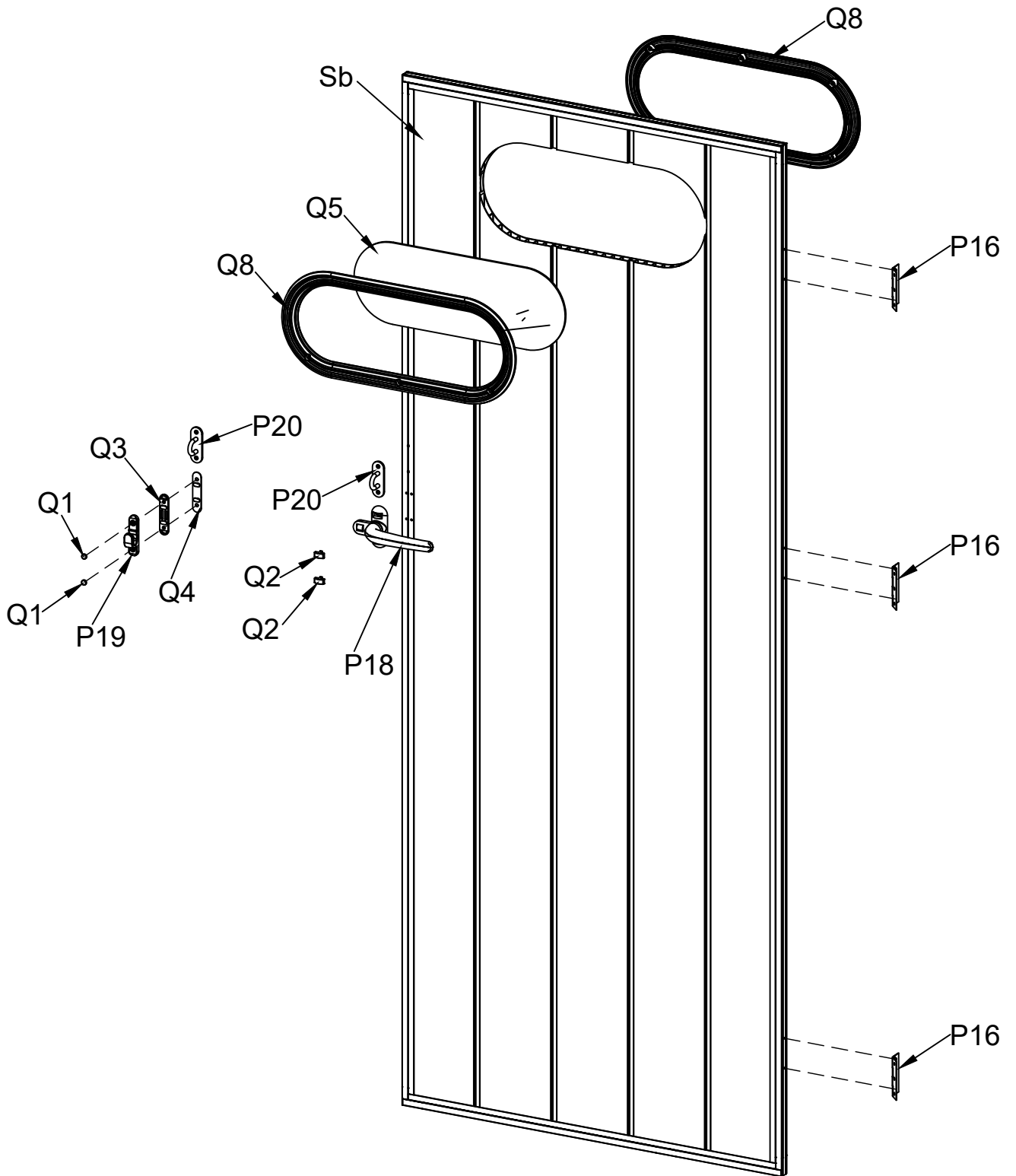

# ASSEMBLY INSTRUCTIONS

A006

05-01

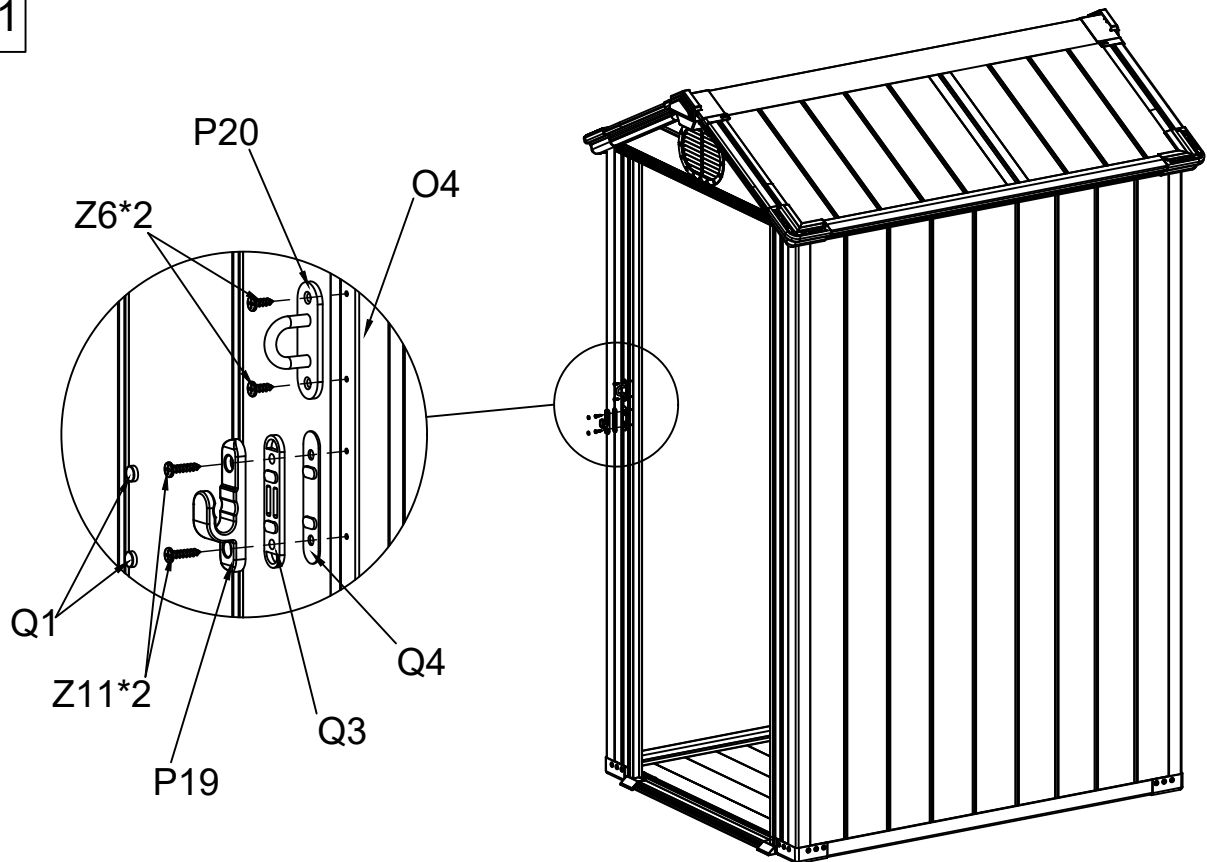

05-02

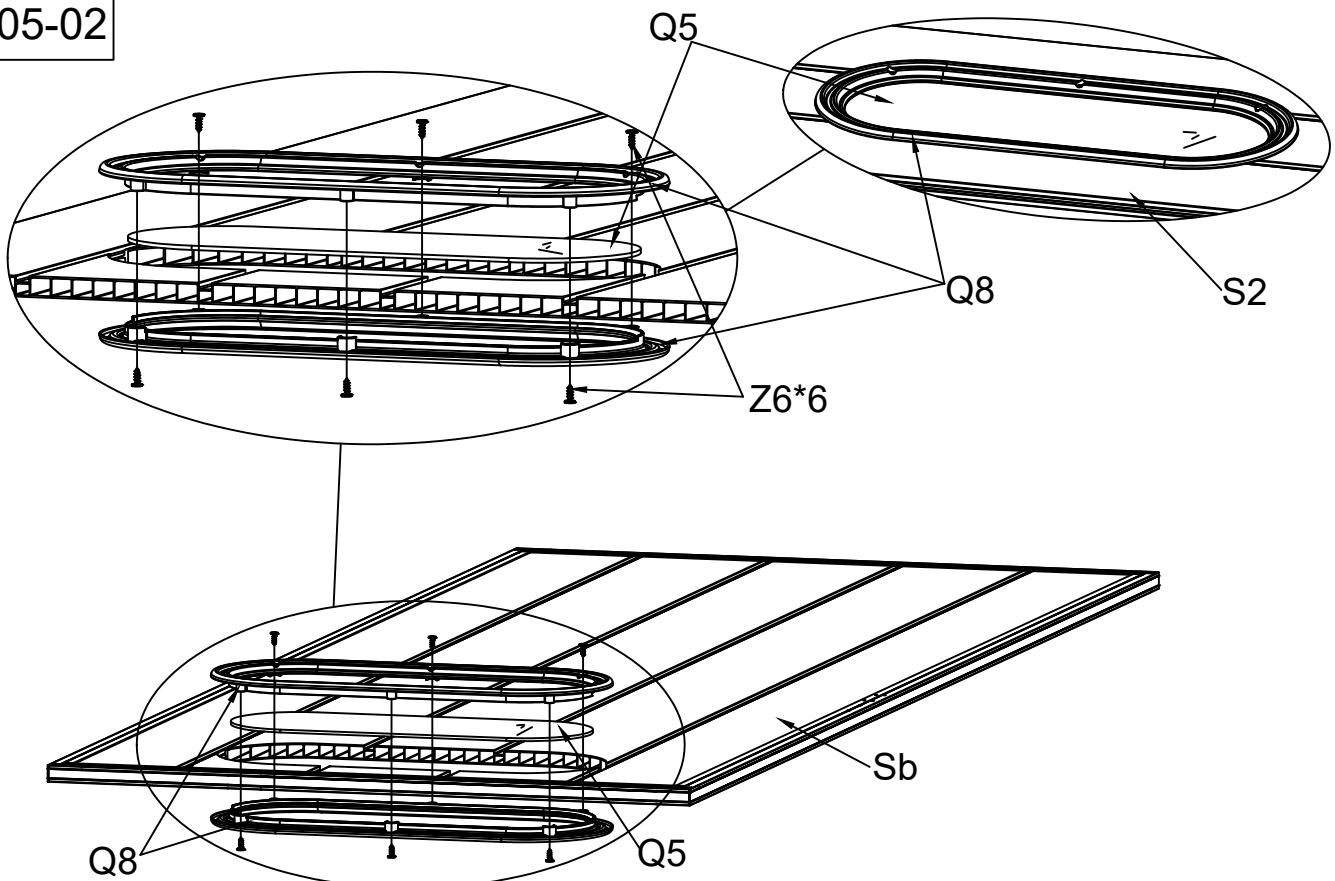

# ASSEMBLY INSTRUCTIONS

A006

05-03

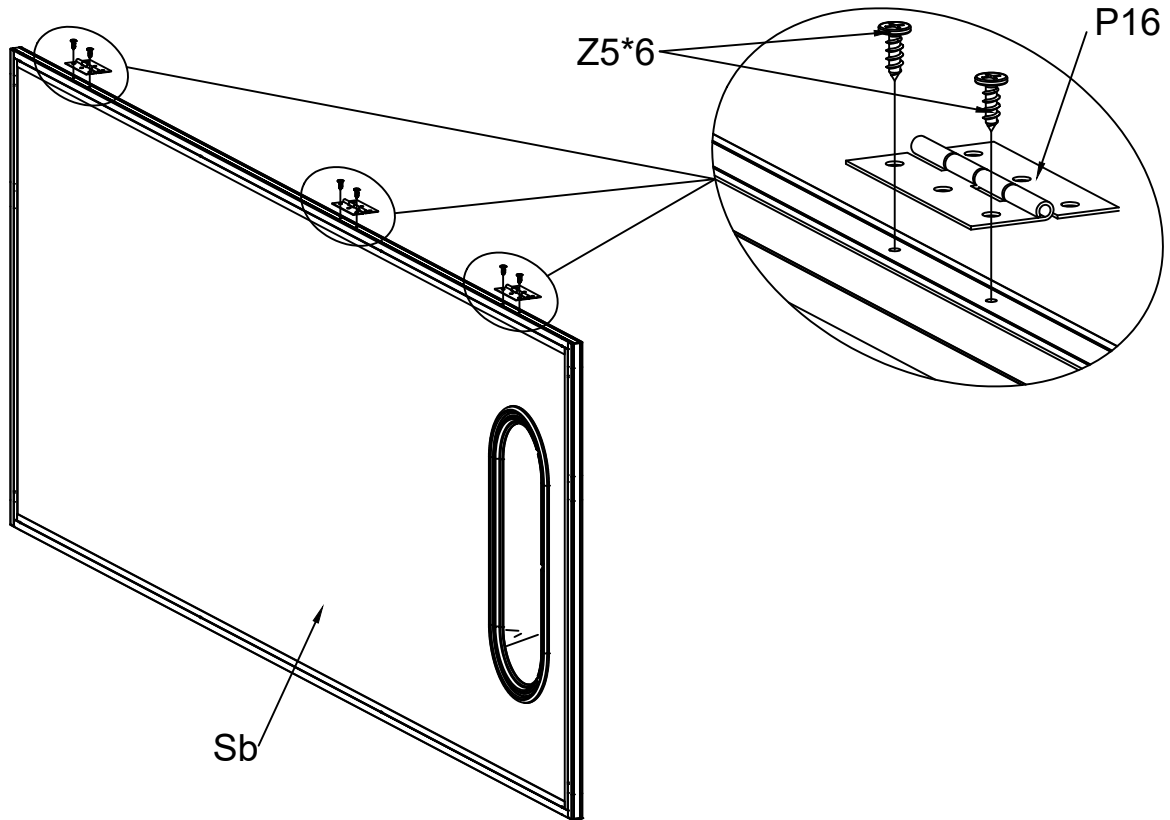

05-04

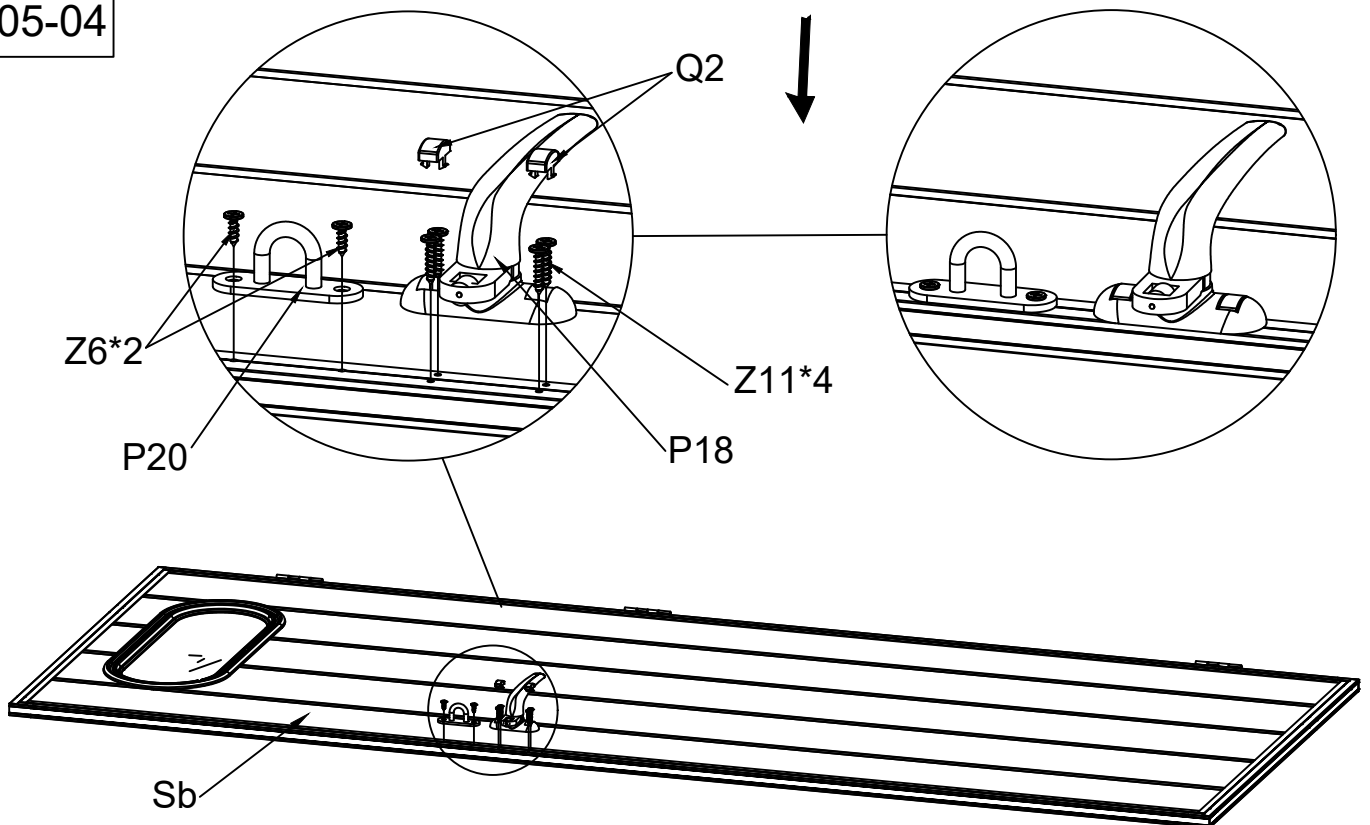

# ASSEMBLY INSTRUCTIONS

A006

05-05

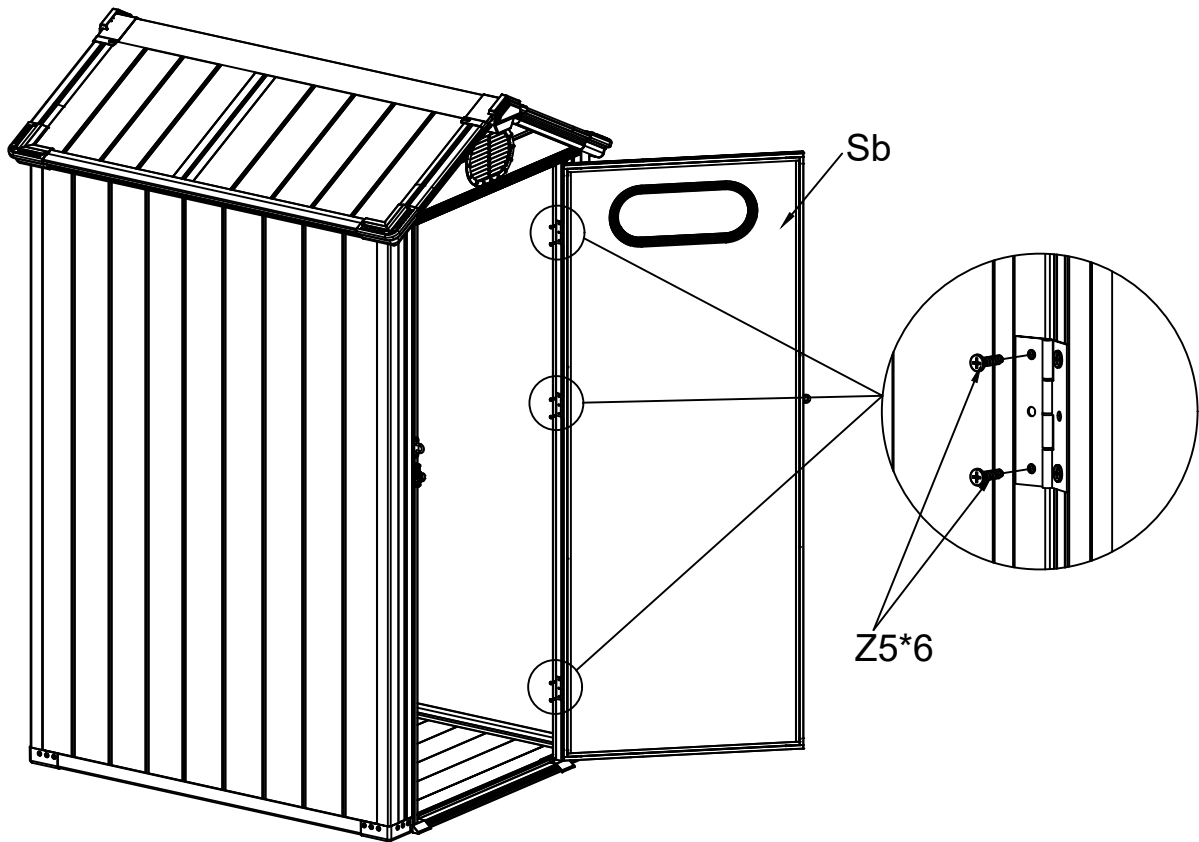

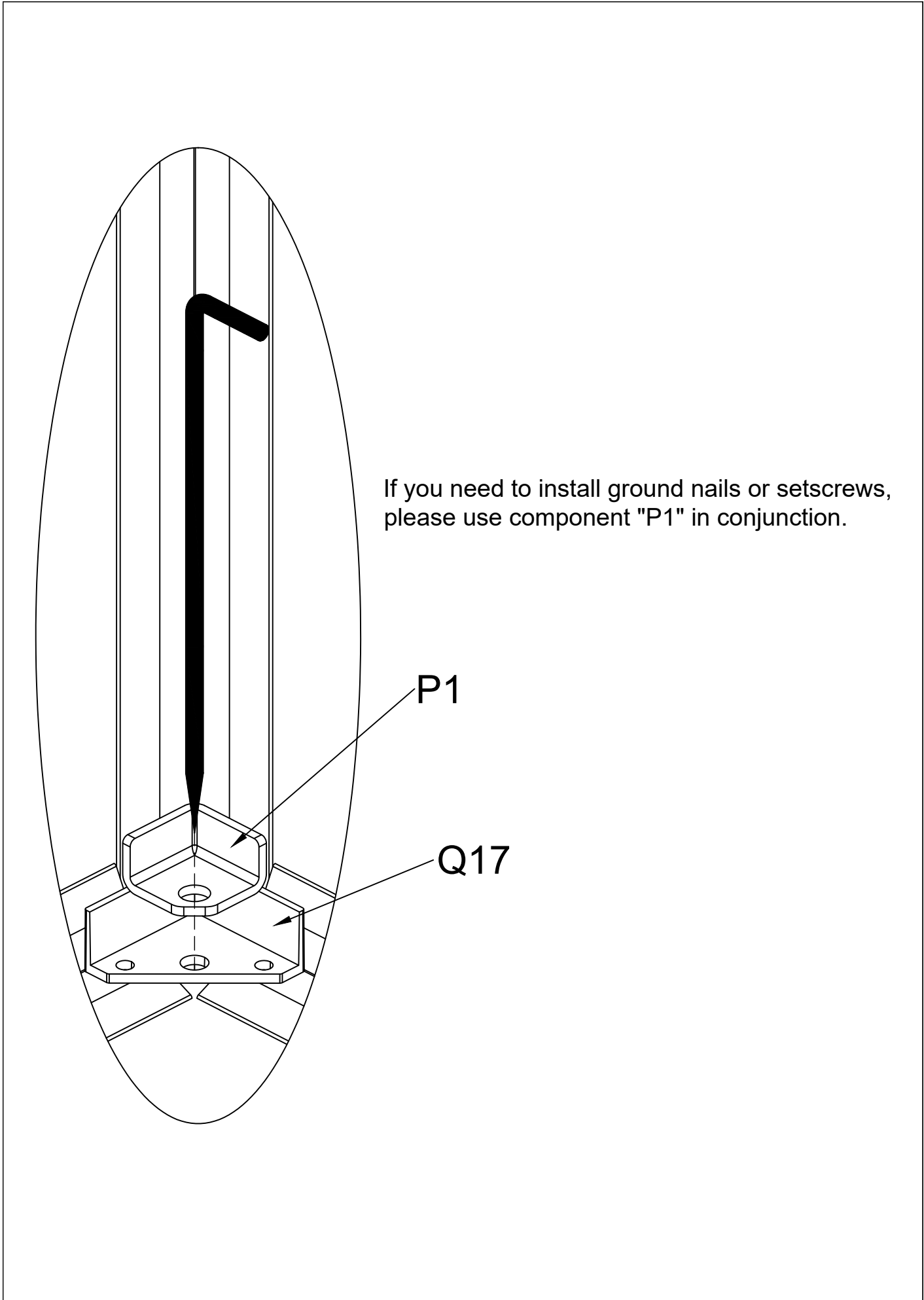

If you need to install ground nails or setscrews, please use component "P1" in conjunction.

P1

Q17











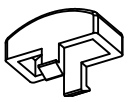

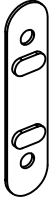
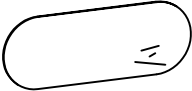
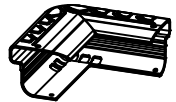
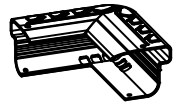
# Packing List

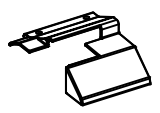
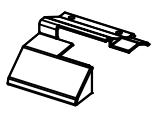
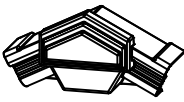
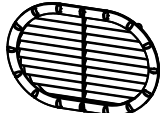
A006

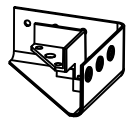
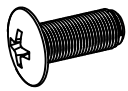
500*15*1775	500*15*492	235*15*918	235*15*918	680*15*1775	682*17*1755
<b>A2 2pcs</b>	<b>A10 2pcs</b>	<b>B10 1pc</b>	<b>B11 1pc</b>	<b>S1 3pcs</b>	<b>Sb 1pc</b>
680*15*492	L=1775			L=1793	L=61
<b>S8 2pcs</b>	<b>C1 4pcs</b>	<b>D5 2pcs</b>	<b>E3 1pc</b>	<b>F1 4pcs</b>	<b>F14 2pcs</b>
L=866	L=1142	L=1144			
<b>F15 1pc</b>	<b>F16 2pcs</b>	<b>G11 2pcs</b>	<b>H5 4pcs</b>	<b>I5 4pcs</b>	<b>J7 1pc</b>
L=914	L=914	L=1775	L=868	51*18*0.8*1197	43*22*868
<b>R3 11pcs</b>	<b>R4 1pc</b>	<b>R5 4pcs</b>	<b>U1 1pc</b>	<b>K14 2pcs</b>	<b>M9 1pc</b>
40*20.2*1765	40*20.2*1765				
<b>O3 1pc</b>	<b>O4 1pc</b>	<b>P1 4pcs</b>	<b>P5 2pcs</b>	<b>P7 2pcs</b>	<b>P8 2pcs</b>
<b>P9 2pcs</b>	<b>P16 3pcs</b>	<b>P18 1pc</b>	<b>P19 1pc</b>	<b>P20 2pcs</b>	<b>Q1 2pcs</b>

# Packing List

A006

					
Q2 2pcs	Q3 1pc	Q4 1pc	Q5 1pc	Q6 2pcs	Q7 2pcs
					
Q8 2pcs	Q10 1pc	Q11 1pc	Q14 2pcs	Q15 1pc	Q16 1pc
	 M6*15	 Ø13*Ø6.5*1.0	 ST4.0*18	 ST4.0*12	 ST4.0*17
Q17 4pcs	Z1 4pcs	Z4 4pcs	Z5 119pcs	Z6 117pcs	Z11 6pcs
					
Za 1pc	Zb 1pc				